

Phoenix Controls air quality sensors control the amount of outside air introduced by a ventilation plant and continuously monitor the indoor air quality of a facility. As a result, air quality improves and system efficiency is optimized. Energy consumption is reduced by eliminating the introduction of excess outside air into the system during periods of little or no occupancy. Online sensing assures improved air quality throughout the facility and can help identify problem areas before reaching a critical stage (examples include contaminants from carpets, equipment, furnishings, and chemicals). The facility manager can also analyze the recorded data from the sensors and adjust building processes for optimum air quality and occupant comfort.

These sensors use a unique oxidizing element that varies in resistance to the contaminant gases detected and are non-specific to any one gas. Instead, the output signal corresponds to the combined concentration of more than 30 contaminant gases typically found in indoor environments (see chart on page 3). This provides a much more accurate representation of the actual air quality than a carbon dioxide (CO₂) sensor, which senses only CO₂ but not other contaminants that could be present. These sensors can be placed in separate rooms and in air ducts.

FEATURES

- Saves energy costs through demand-based control of an outside air intake
- Improves and optimizes the air quality in facilities
- Increases worker productivity through improved comfort
- Responds to more than 30 different contaminants
- Allows early detection of potential air quality problems

SPECIFICATIONS

Signal 0-10 V DC representing 0-100% air pollution	Storage Temperature 10-150 °F
Supply Voltage 24 VAC (+10%, -50%) 24 DC (12-24 V)	Ambient and Storage Humidity 5-95% RH (non-condensing)
Power Consumption 1 VA or less	Housing Material Body—Lexan Probe—ABS
Minimum Load Resistance 4 kΩ	CE
Ambient Temperature 32-140 °F	

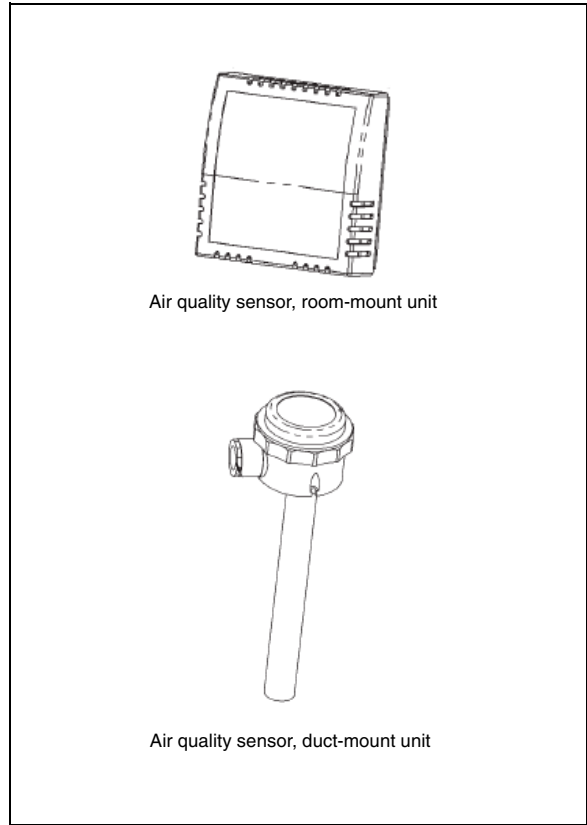

Air quality sensor, room-mount unit

Air quality sensor, duct-mount unit

ORDERING GUIDE

Part Number	Description
AQS100-R	Room air quality sensor*
AQS100-D	Duct air quality sensor*

* Requires PVC100-HW.

TABLE OF CONTENTS

Applications and Operation 2
 Dimensions 4
 Installation 4
 Points and Wiring 5
 Maintenance 6

APPLICATIONS AND OPERATION

Construction

The transmitter circuitry, which utilizes surface mount technology, is supported by a rigid circuit board. In the room sensor, it is fixed to a surface pattern base plate suitable for wall mounting. A ventilated cover provides physical protection to the components while allowing sufficient air flow for detection purposes. In the duct mount sensor, the circuit board is protected by a polycarbonate housing with a removable cover. A threaded conduit entry is provided for electrical connection. The sensing element is positioned at the tip of the duct tube and is protected by a sintered filter. This filter serves to control the effects of high air velocity and to prevent dust build-up.

Function

The sensing element is a specially developed sintered semiconductor that, when heated to a predetermined temperature, causes the gases to oxidize on the surface coating of tin dioxide (SnO_2). This causes a change in conductivity and the resultant resistance is fed into an amplifier and output as a 0 to 10 Vdc signal proportional to contamination. The amplifier incorporates a rate of rise circuit to filter out short term disturbances and provide a stable output (the damped output).

Total Contaminant Sensing

The concept of a total contaminant sensor is to detect a wide variety of contaminants that are typically found in indoor environments. These include:

- Volatile Organic Compounds (VOCs) emitted by detergents, paints, cleaners, new carpet, air fresheners, disinfectants, carpet and tile adhesives, solvents and tobacco smoke.
- Other gases: CO_2 , ammonia, chlorine carbon monoxide, methane formaldehyde.

A sensor that can detect these items can provide a more representative indication of actual air quality conditions than a sensor that detects only one item, such as CO_2 .

Application

The purpose of the air quality sensor is to control the amount of fresh air introduced by a ventilation plant and to reduce energy consumption. This is achieved by measuring the level of contaminant gases found in the controlled space and providing a signal to the Phoenix Controls Celeris system to reduce the volume of air supplied to the space, thereby saving on the energy consumed by heating or cooling fresh air during periods of little or no occupancy.

The principal feature of the air quality sensor is that a *mixed gas* level is monitored and not any specific gas. The sensor, therefore, does not distinguish between contamination from substances, such as tobacco smoke, cooking smells, or people, but provides the air correction necessary for comfort, as well as health with various gases present.

Important:

These sensors are not designed or intended for use in safety systems where personal injuries may result.

Using the air quality sensor

The air quality sensor is a total contaminant sensor. It is sensitive to a large variety of gases and contaminants that are typically found in indoor environments and outputs a signal in relation to the concentration of those contaminants. This table lists the contaminants and concentrations to which the air quality sensor responds.

Description	Concentrations (parts per million)												
	1	5	10	20	50	100	200	500	1 K	3 K	5 K	7 K	10 K
Combustibles													
Iso-butane								•	•	•	•	•	•
Methane								•	•	•	•	•	•
Ethane								•	•	•	•	•	•
Propane								•	•	•	•	•	•
Ethylene								•	•	•	•	•	•
Hydrogen								•	•	•	•	•	•
Carbon monoxide					•	•	•	•	•	•	•	•	•
Methyl ether								•	•	•	•	•	•
Hydrocarbons													
Vinyl chloride	•	•	•	•	•	•	•	•	•				
Methyl chloride	•	•	•	•	•	•	•	•					
Methylene chloride					•	•	•	•	•	•	•		
Ethylene oxide								•	•	•	•		
Acrylonitrile			•	•	•	•	•	•	•				
Other Gases													
Hydrogen sulfide		•	•	•	•	•	•	•					
Carbon dioxide								•	•	•	•	•	•
Sulfur dioxide		•	•	•	•	•	•	•					
Chlorine	•	•	•	•	•								
Ammonia				•	•	•		•	•	•	•		
Liquids													
Acetone				•	•	•	•	•	•	•			
Methanol				•	•	•	•	•	•	•			
n-Pentane				•	•	•	•	•	•	•			
n-Hexane				•	•	•	•	•	•	•			
Benzene				•	•	•	•	•	•	•			
Meth. eth. ketone				•	•	•	•	•	•	•			
Dimethyl amine				•	•	•	•	•					
Ethanol				•	•	•	•	•	•	•	•	•	•
Methyl acetate					•	•	•	•	•	•			
Freons													
Various								•	•	•	•	•	•
Other Contaminants													
Tobacco smoke, alcohol, formaldehyde and perfumes													

DIMENSIONS

Air Quality Sensor (room mount enclosure shown on left; duct mount enclosure on right)

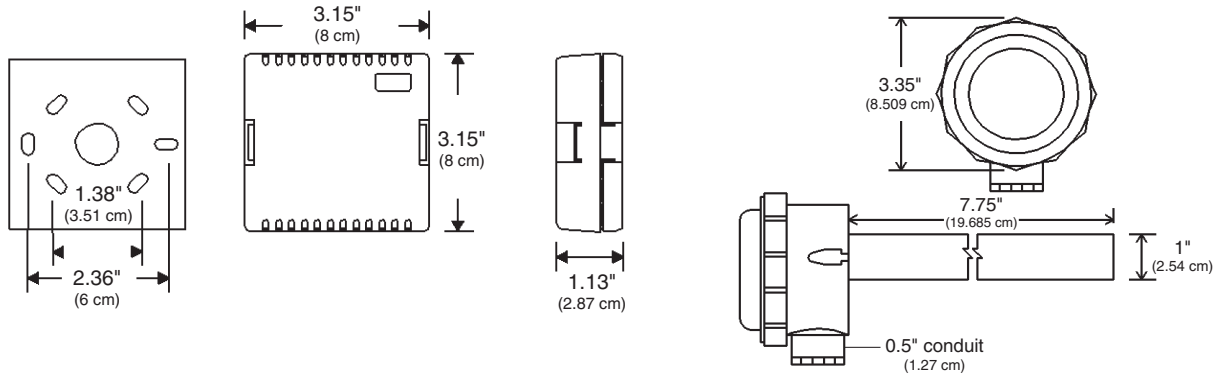

INSTALLATION

Room Installation

The room sensor should be mounted at a height of five feet from the floor of the area to be controlled, away from doors, opening windows, supply grilles or other known disturbances.

Duct Installation

1. The duct sensor should be mounted in the return air duct of the area or areas to be controlled in an accessible location suitable for maintenance.
2. Although the sensor has a filter, locations where oil and grease will foul the filter, such as kitchen hoods, should be avoided.

POINTS AND WIRING (see submittal wiring diagram for project-specific details)

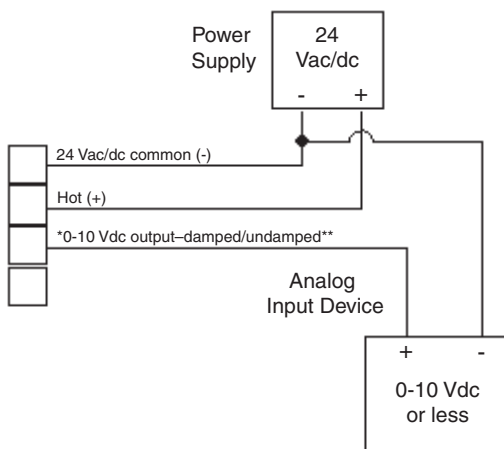

POINTS AND WIRING (CONTINUED)

Termination

Phoenix Controls recommends using twisted pair of at least 22 AWG and crimp type connectors for all wire connections. Also, it is recommended that wiring *not* be run in the same conduit as line voltage wiring or with wiring used to supply highly inductive loads, such as motors, generators, and coils.

Terminal Blocks

TB	Function
1	Ground
2	Power (24 Vac or Vdc)
3	Signal (factory set to 0 to 10 volts; see Field Calibration section)

Note:

If the power supply is shared with devices that have coils (relays, solenoids, etc.), each coil must have a diode, MOV, Transorb, or other spike snubbing device. Failure to use a spike snubbing device could result in malfunction or destruction of the electronic circuits due to voltage spikes. The secondary voltage of the transformer should be from 22 to 28 volts and isolated from earthground, chassis ground, and neutral leg of the primary winding. Grounding should be to the system common only. Failure to follow these procedures can result in improper operation.

Jumper Positions

Jumper	Function
LK1	Upper position—Operate Lower position—Test (for factory use only)
LK2	On—Damped output Off—Undamped output

Potentiometers

Setting	Function
CAL	Adjusts for background contamination
GAIN	Factory set— Do not adjust
SPAN	Controls maximum voltage output

Note:

These sensors are not designed or intended for use in safety systems where personal injury may result.

Room Configuration

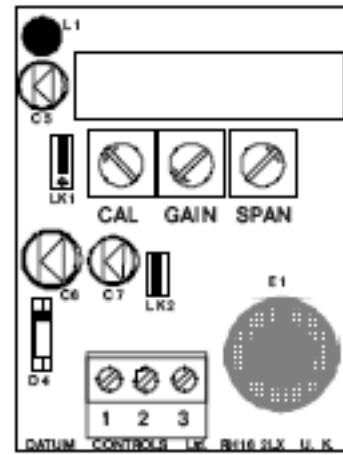

Duct Configuration

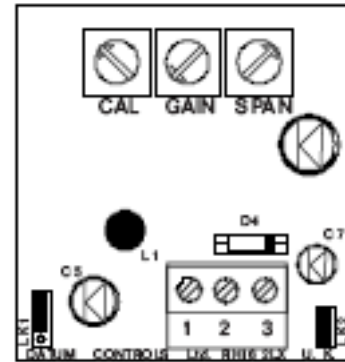

Field Calibration

Air quality sensors are factory calibrated for use under average room conditions. If recalibration onsite is necessary, an initial burn-in time of seven days should be allowed before making final adjustments. Rough calibration is possible after 30 minutes of operation.

To change the calibration (offset) to allow for background contamination:

1. Keep the jumper shunt on LK2 (unit in damped mode).
2. Make a small adjustment to the CAL potentiometer.
3. Wait one minute and then measure the voltage on terminal 3.
4. Repeat steps 2 and 3 until the desired minimum voltage is reached.

Note:

Adjustment of the CAL potentiometer should be done at a time when the conditions surrounding the air quality sensor are at a minimum contamination (contamination level for minimum fresh air).

To change the output span to something other than 0 to 10 Vdc:

1. Remove the jumper shunt from LK2.
2. Move the jumper shunt from pins 1 and 2 of LK1 to pins 2 and 3 of LK1.
3. Adjust the SPAN potentiometer until the desired maximum voltage is measured on terminal 3.
4. Move the jumper shunt from pins 2 and 3 of LK1 back to pins 1 and 2 of LK1.
5. Reinstall the jumper shunt on LK2.

Note:

The minimum span is 0 to 1.5 V, maximum span is 0 to 10 V (factory default). Units can be ordered with a factory set 0 to 5 V span, call Phoenix Controls for details.

MAINTENANCE

Phoenix Controls sensors require no ongoing preventative maintenance. Once the field engineer has completed the field setup, these units will provide years of continuous operation.