

The Phoenix Controls Drive Interface Board (DIB100) provides signal conditioning for all applications utilizing a variable speed drive. The DIB100 consists of an interface card installed in an enclosure that is mounted on top of a fume hood or adjacent to the drive (see right).

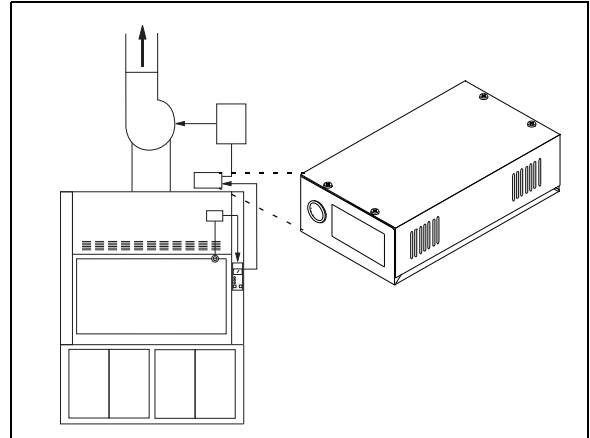

DIB100 as part of a fume hood exhaust system.

FEATURES

The Phoenix Controls DIB100 has the following features:

- Provides buffering and filtering to all non-grounded signals connected to the drive.
- Serves as a junction point between the variable speed drive and the Phoenix Controls fume hood monitor, make-up air controller, or tracking valve.

APPLICATION

The DIB100 is strictly for use with the PCD300 series variable speed drive. Contact Product Support for your application.

- Drive systems in applications with make-up air controllers or tracking valves power the fume hood monitor from the system power supply through the DIB100 connections.
- Standalone drive system applications require a wall-mounted power supply to power the fume hood monitor and DIB100.

ORDERING GUIDE

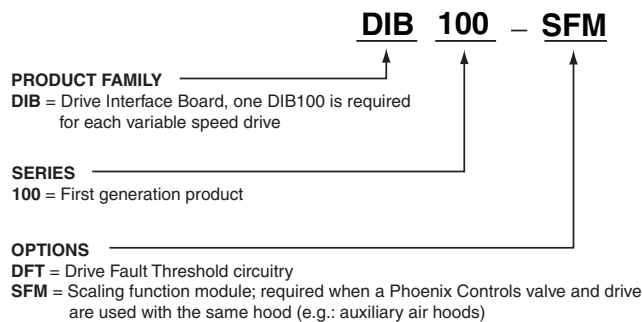

SPECIFICATIONS

Enclosure
 NEMA-1

Dimensions
 10" L x 6" W x 3.2" D (254 x 152 x 81 mm)

Approx. Weight
 6 lbs. (2.6 kg)

Operating Range
 32-122 °F (0-50 °C) ambient

Power Requirements
 ± 15 Vdc, ±5%, @ 0.010 amp

TABLE OF CONTENTS

| | |
|--------------------------------------|---|
| Installation | 2 |
| Points & Wiring | 2 |
| Maintenance and Troubleshooting..... | 2 |

INSTALLATION

Install the unit in an area where it will be protected from:

- direct sunlight, rain, or moisture
- corrosive gases or liquids
- extreme temperatures
- vibration, airborne dust, or metallic particles

The unit must have a minimum clearance of one inch (2.54 cm) around each vented side. Leave a minimum of 3 feet (1 m) between the DIB100 and the variable speed drive.

Remove the cover and mount the back plane with four mounting screws. Terminate all wiring and replace cover.

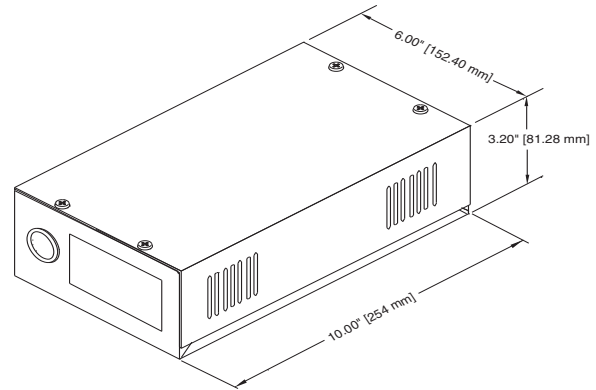

POINTS & WIRING

Phoenix Controls Variable Speed Drive

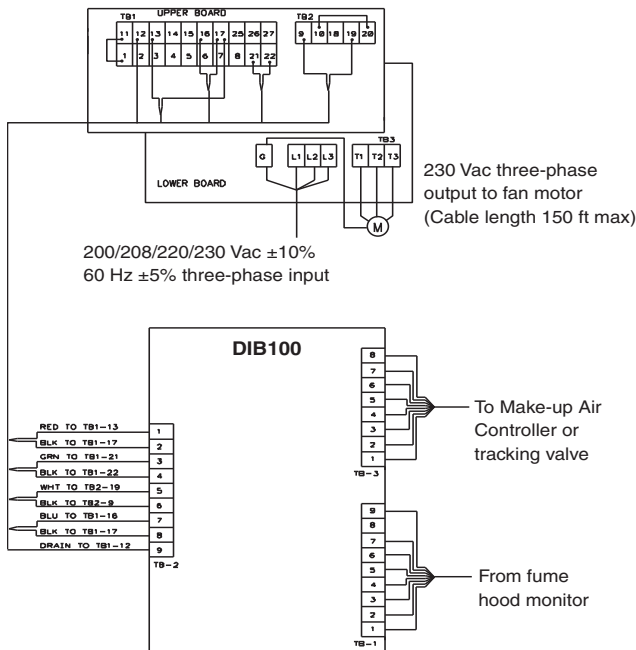

DIB100 typical wiring diagram.

TERMINAL BLOCK POINTS

| | 1 | 2 | 3 | 4 | 5 | 6 | 7 | 8 | 9 |
|---------------------------------|-------|--------------|------|---------------|-------|----------------|-----------------|----------------|----------------|
| TB1 (monitor) | +15 V | GND | -15V | CMD | FDBK | Alarm | Fault thres. | — | Sash posit. |
| TB2 (drive) | CMD | CMD comm. | FDBK | FDBK comm. | Alarm | Alarm comm. | Fault thres. | F.T. comm. | Cable drain |
| TB3 (MAC or valve) | +15 V | GND | -15V | CMD | FDBK | Alarm | — | Sash posit. | N/A |

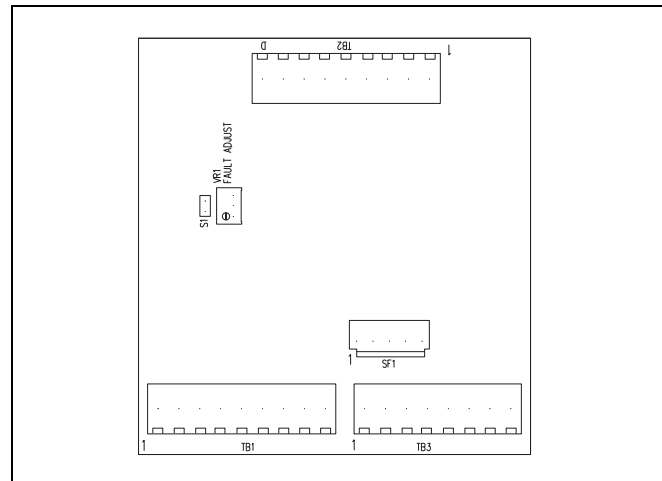

MAINTENANCE

The DIB100 requires no ongoing preventative maintenance. Once the field engineer has completed the field setup, the DIB100 will provide years of continuous operation. Replacement boards are available.

| Replacement Part | Part Number |
|------------------|-------------|
| DIB board | 800-230-012 |

TROUBLESHOOTING

Refer to the X30 Series Fume Hood Monitors product data sheet for system troubleshooting.