

The Phoenix Controls Traccel® Family of Valves is designed specifically for the ventilation requirements of demanding spaces in life science lab facilities, where ventilation zone control, energy savings and reducing maintenance costs are an important part of business operations.

These valves provide a safe, comfortable working environment for research in a single standalone lab or an entire research complex. The flexibility, airflow turndown, and added configuration options make it an ideal solution for modular mixed-use facilities.

Life science research spaces designed with an open lab and fume hood alcoves require a unique ventilation control solution. As airflow or pressurization requirements change, the impact on adjacent spaces like bench work areas, offices, and common corridors contribute directly to the balance of the entire lab. The adjacent spaces must adapt to airflow changes controlled by critical spaces like fume hood alcoves.

The Traccel Family of Valves is a cost-effective platform for ventilation control applications for these adjacent spaces. It uses the LonWorks® Communication Protocol to develop peer-to-peer control architecture with high-speed Celeris® or normal-speed Traccel Valve Controllers for the desired research space control strategy.

System Benefits

- Factory characterization reduces system commissioning time
- Pressure-independent valves avoid rebalancing costs
- No flow sensors to maintain
- High turndown ratios contribute to reducing energy costs
- Flexibility to handle space configuration changes

PRODUCT MODELS

Three venturi valve options are available in the Traccel family:

PRODUCT	DESCRIPTION
Traccel-TP (Tracking Pair VAV)	To meet the need of directional airflow, Traccel-TP features tracking valve pairs that maintain a prescribed CFM offset to enable accurate space pressurization and complete room climate control.
Traccel-TX (Enhanced Tracking Pair VAV)	For tracking pair applications in demanding spaces, Traccel-TX provides extra I/O to meet the needs of humidity control and pressure monitoring, plus optional shut-off capability for decontamination procedures.
Traccel-SO (Supply-only VAV)	In VAV applications where ducted exhaust is sufficient to meet local codes and engineering guidelines, Traccel-SO provides a cost-effective supply valve when no tracking exhaust valve is required.

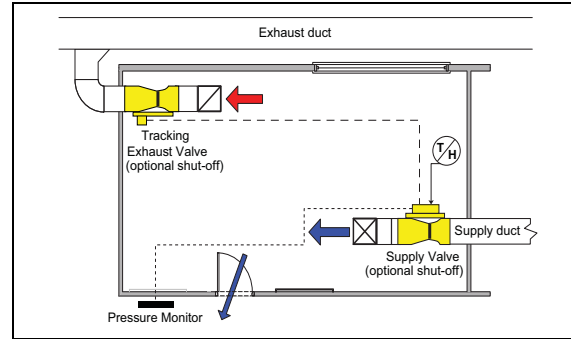

The Traccel-TX valve can maintain a positive, negative, or neutral directional airflow with variable air volume (VAV) temperature and humidity control. More room control applications are described on page 4.

SPECIFICATIONS

Construction (includes A and S valve designs)

- 16 ga. spun aluminum valve body with continuous welded seam
- Aluminum valve bodies available as uncoated aluminum or with corrosion-resistant baked phenolic coatings
- Composite Teflon® shaft bearings
- Spring grade stainless steel spring and PPS slider assembly
- Supply valves insulated with 3/8"(9.5 mm) flexible, closed-cell polymer-based foam. Flame/smoke rating 25/50. Density is 1.5 lb/ft³ (24.0 kg/m³).

Construction, Low-leakage (L valve designs)

(Save as above with the following added)

- Cone gasket material:
 - Class A: Neoprene
 - Class B: Viton
- Seal wheel material: Polypropylene

Operating Range

- 32-122 °F (0-50 °C) ambient
- 10-90% non-condensing RH

(Specifications continued on page 2)

TABLE OF CONTENTS

Product Models 1
 Specifications 1
 Features 3
 Available Inputs and Outputs 3
 Applications 3
 Ordering Guide 5
 Shut-off Leakage Performance 6
 Wiring 10
 Points 15
 LonMark Objects and Network Variables 19
 Maintenance 21

SPECIFICATIONS (CONTINUED)

Performance

- Pressure independent over a 0.3"-3.0" WC (74-747 Pa) drop across valve
- Volume control accurate to $\pm 5\%$ of airflow command signal
- No additional straight duct runs needed before or after valve
- Available in flows from 35-10,000 CFM (59-16,990 m³/hr)
- Response time to change in command signal: <1 minute

Sound

Designed for low sound power levels to meet or exceed ASHRAE noise guidelines

Room-level Communications

FTT-10, 78 KB, LonTalk™ network

Power

- 24 Vac ($\pm 15\%$) @ 50/60 Hz

Power Consumption (singles and duals)

- SO – (one controller/one actuator): 10 VA
- TP, TX – (one controller/two actuators): 12 VA

Notes:

1. All power consumption VA ratings listed here are based on fully-loaded I/O except for floating point reheat actuators.
2. VA ratings for floating point reheat actuators must be factored in separately.

Input Accuracy

Voltage, current, resistance: $\pm 1\%$ full scale

Output Accuracy

- 0 to 10 Vdc: $\pm 1\%$ full scale into 10 K Ω minimum
- 4 to 20 mA: $\pm 1\%$ full scale into 500 Ω +0/-50 Ω

Interoperability

- Based on LONWORKS technology for peer-to-peer communication between room controllers
- LonMark® certified according to the Interoperability Guidelines Version 3.4
- LonMark functional profile SCC-VAV #8502

Agency Compliance

- CE
- CSA
- Optional IP54 Controller Protection

FCC COMPLIANCE

This device complies with part 15 of the FCC Rules. Operation is subject to the following two conditions:

1. This device may not cause harmful interference.
2. This device must accept any interference received, including interference that may cause undesired operation.



Teflon is a registered trademark of DuPont Co.

LONWORKS is a registered trademark of Echelon Corp.

LONMARK and the LONMARK Logo are managed, granted, and used by LONMARK International under a license granted by Echelon Corporation.

FEATURES

FEATURE	TRACCEL MODEL	DESCRIPTION
Pressure independence	All	CFM airflow maintained regardless of changes in duct static pressure.
No flow sensors	All	Factory flow characterization eliminates the need for flow sensors.
Airflow offset maintained	TP, TX	Supply and exhaust CFM offset settings maintain accurate pressurization.
Temperature and occupancy control	TP, TX, SO	Primary and secondary PID loops. Occupied, unoccupied or standby. Building Management System (BMS) or local set point input.
Humidity control and pressure monitoring	TX	Humidity monitoring and control. Pressure monitoring. BMS control available.
HVAC emergency modes	TP, TX, SO	Multiple modes available. Custom setup for each mode.
Floating point reheat	TP, TX, SO	Control algorithm and TRIAC support for tri-state hydronic reheat valves.
Flexible I/O	TP, TX, SO	Up to 14 Standard LON Network Variable Types (SNVT) per I/O point available to read/write via LonTalk.
Additional inputs/outputs (I/O)	TX	Two additional universal inputs (humidity, pressure).
Shut-off capability	TX	Optional shut-off valve configuration enables room decontamination procedures.

TP = Tracking pair VAV
 TX = Enhanced tracking pair VAV
 SO = Supply-only VAV

AVAILABLE INPUTS AND OUTPUTS* (BASED ON TRACCEL BOARD)

TYPE		DESCRIPTION
Universal input	UI 1	Dry contact ($\leq 100 \Omega$ = Closed, $\geq 100 K\Omega$ = Open), 0-10.5 Vdc, 4-20 mA, Thermistor NTC2 and 3 (resistance 0-10 K Ω)
Universal input	UI 2	Same as UI 1
Universal input	UI 3	Same as UI 1
Universal input	UI 4** (TX Only)	Same as UI 1; for humidity sensor or spare
Universal input	UI 5** (TX Only)	Same as UI 1; for Active Pressure Monitor (APM) pressure sensor or spare
Digital input	DI 1	Dry contact ($\leq 100 \Omega$ = Closed, $\geq 100 K\Omega$ = Open); logic level (≤ 0.7 Vdc = OFF, ≥ 1.4 Vdc = ON)
Analog output	AO 1	0-10.5 Vdc, 4-20 mA
Analog output	AO 2	Same as AO1
Digital output	DO	Type C, 1 Amp @24 Vac/Vdc
TRIAC 1	Main valve control	TRIAC to control main low-speed actuator
TRIAC 2	Tracking valve control	TRIAC to control tracking low-speed actuator
TRIAC 3	Floating point reheat control	TRIAC to control 24 Vac floating point actuator for reheat valve; 6 VA max @ 24 Vac

* The flow tracking function does not use any of the inputs or outputs above. For more details, see the wiring diagrams starting page 10.

** Available only on Traccel-TX.

APPLICATIONS

Pressure Independence

Phoenix Controls venturi valves use a simple mechanical regulator to compensate for the changes in static pressure, so accurate flow control is assured at all times.

Unlike commercial controls that use velocity pressure sensors mounted in the airstream, venturi valves are impervious to dust, dirt and sensor drift. Phoenix Controls valves continue to work even in the event of a power failure, assuring that the correct room pressurization and directional airflow are maintained at all times.

Unique 48-point flow characterization curves for the supply and exhaust valves serving the room are downloaded to every Traccel controller's on-board microprocessor before the valves leave the factory. The controller uses this flow data to accurately control flow-tracking between the two valves, virtually eliminating field calibration and rebalancing.

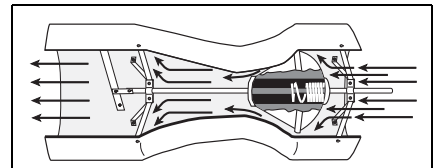

APPLICATIONS (CONTINUED)

Tracel-TP VAV tracking pair

Temperature control flexibility with multiple cooling zones

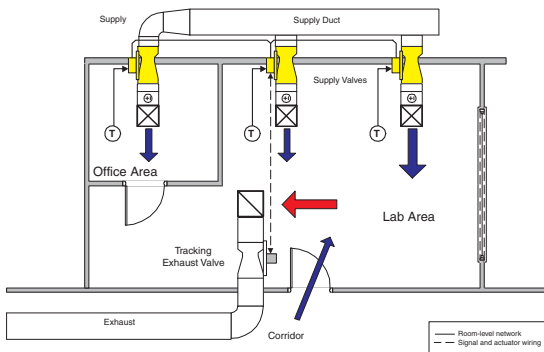

Sometimes in larger spaces, temperature gradients vary within the space. In these applications, multiple temperature zones can be used to provide local cooling where needed. In these applications, Tracel Controllers work together to sum the total supply volume for three temperature zones and modulate one exhaust valve to maintain correct directional airflow.

Tracel -TX Enhanced VAV tracking pair

Life Science applications

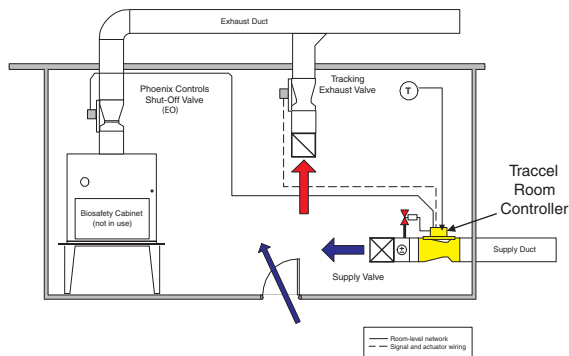

In this example, a Phoenix Controls Shut-off Valve is used to isolate the BSC exhaust flow when it is not in use. The Shut-off Valve communicates over the room level network with the Tracel Room Controller, which compensates for the change in flow to maintain room airflow balance and ensures correct directional airflow into or out of the room.

Tracel-SO VAV office space adjacent to open lab

Standalone supply with ducted return

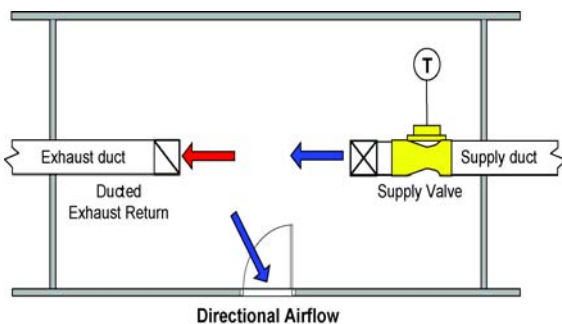

This office space has a standalone Tracel-SO valve on the supply side and a ducted return on the exhaust side. The Tracel-SO valve can have an associated temperature sensor and control a hot water valve. An optional temperature sensor can be placed in the ductwork to monitor duct temperature either on the supply or exhaust side.

ORDERING GUIDE

TSV A 2 10 M - A L E H Z - R E I

VALVE FAMILY

TSV = Traccel Supply valve
(comes standard with insulation)
TEV = Traccel Exhaust valve

VALVE CONSTRUCTION

A = Body and cone uncoated aluminum;
shaft uncoated 316 stainless steel
B = Body and cone with baked-on phenolic coating;
PFA-coated 316 stainless steel shaft

NUMBER OF VALVE BODIES

F = One valve body with a welded circular flange
1 = One valve body, no flange
2 = Two valve bodies (dual), available for 10", 12", and 14" valves only

VALVE SIZE

08 = 8" valve (7.88"/200mm actual diameter); see Note 1
10 = 10" valve (9.67"/246mm actual diameter)
12 = 12" valve (11.84"/301mm actual diameter)
14 = 14" valve (13.88"/353mm actual diameter); see Note 2

FLOW/PRESSURE OPERATING RANGE

See *Flow/Pressure Operating Range* tables in this section.

M = Medium pressure operation; pressure independent over a range of 0.6 to 3.0" WC (150 to 750 Pa), associated pressure switch trips at 0.3" WC
L = Low pressure operation; pressure independent over a range of 0.3 to 3.0" WC (75 to 750 Pa), associated pressure switch trips at 0.2" WC; see Notes 3, 4

VALVE OPTIONS

EVI = Exhaust valve with insulation blocks and insulation
IBO = Insulation blocks only, no insulation
PSL = Pressure switch, low limit
REI = Remote electronics - indoor; see Note 5
WRE = Weather-resistant electronics - outdoor; see Notes 6, 7
SFB = Square flanges on each end of single body valves
SFX = Single square flange on a single body valve mounted on either the inlet of exhaust valves or discharge of supply valves

FAIL SAFE POSITION

Z = Fails to last position

VALVE ORIENTATION

H = Horizontal
U = Vertical upflow
D = Vertical downflow

VALVE CONTROLLER DESIGNATION

E = Traccel TP Supply (controlling valve of tracking pair)
X = Traccel TX Supply (controlling valve of tracking pair with expanded features)
O = Traccel SO Supply only (no tracking pair ability)
N = No electronics (tracking exhaust valve, must be purchased with a supply valve)

CONTROL TYPE

I = IP54 electric actuator; available for single-body 8-, 10-, and 12-inch valves only
L = Low speed electric actuation

VALVE DESIGN

A = Conical-shaped diffuser (Accel II)
S = Standard shut-off valve (metal-on-metal seal)
L = Low-leakage shut-off valve (gasketed seal)

NOTES:

- 8-inch Shut-off Valves (Design = S or L) are available ONLY in Construction A (uncoated).
- 14-inch Valves are currently NOT available as Low Leakage Shut-off (Design = L) with Medium Pressure (Range = M).
- Low Pressure (Range = L), Standard Shut-off (Design = S) valves are NOT available in Orientation = U (vertical upflow)
- Low Pressure (Range = L), Low Leakage (Design = L) valves are currently NOT available in any size.
- Option REI: Remote Electronics, Indoor installations ONLY. The distance to the valve controller is limited to:
 - 150 feet (45.7 meters) of 22 gauge cable for low-speed electric actuators (Control Type = L or I).
- Option WRE: Weather Resistant Electronics, outdoor installations. Applies to ELECTRICALLY actuated valves with sufficient IP ratings only.
 - HORIZONTAL orientation ONLY.
 - Includes sealed Vpot and large weather-resistant IP66 box mounted on the base channel that houses the controller and all electric connections to/from it.
 - When used in Low-Speed Electric applications for 08-, 10-, and 12-inch single-body valves, WRE must ALSO be ordered with Control Type I (IP54 actuator) in place of the standard Control Type L.
 - REQUIRES use of a dog house enclosure, provided by others, to protect valve from the elements and maintain temperature and humidity conditions within Phoenix's specifications.
- Option WRE with Traccel valves is limited to Valve Controller Designation = E, O, or X ONLY.

ORDERING GUIDE (CONTINUED)

Flow/Pressure Operating Range Tables

FLOW/PRESSURE OPERATING RANGE FOR VALVE DESIGN A

Designation	Size	Operating Range in CFM (m ³ /hr)		Pressure Drop Across Valve
		Single	Dual	
M = Medium pressure	08"	35-700 (60-1185)	—	0.6-3.0" WC (150-750 Pa)
	10"	50-1000 (85-1695)	100-2000 (170-3390)	
	12"	90-1500 (155-2545)	180-3000 (310-5090)	
	14"	200-2500 (340-4245)	400-5000 (680-8490)	
L = Low pressure	08"	35-500 (60-845)	—	0.3-3.0" WC (75-750 Pa)
	10"	50-550 (85-930)	100-1100 (170-1860)	
	12"	90-1050 (155-1780)	180-2100 (310-3560)	
	14"	200-1400 (340-2375)	400-2800 (680-4750)	

FLOW/PRESSURE OPERATING RANGE FOR SHUT-OFF VALVE DESIGNS S AND L

Designation	Size	Operating Range in CFM (m ³ /hr)		Pressure Drop Across Valve
		Single	Dual	
M = Medium Pressure	08"	35-600 (60-1015)	—	0.6-3.0" WC (150-750 Pa)
	10"	50-850 (85-1440)	100-1700 (170-2880)	
	12"	90-1300 (155-2205)	180-2600 (310-4410)	
	14"	200-1600 (340-2715)	400-3200 (680-5430)	
L = Low Pressure	08"	35-400 (60-675)	—	0.3-3.0" WC (75-750 Pa)
	10"	50-450 (85-760)	100-900 (170-1520)	
	12"	90-900 (155-1525)	180-1800 (310-3050)	
	14"	200-1000 (340-1695)	400-2000 (680-3390)	

SHUT-OFF LEAKAGE PERFORMANCE

Shut-off Valves are available in two designs: Standard (Option S) and Low Leakage (Option L). The shut-off can be initiated either locally through a universal input (UI) from the building management system (BMS) or remotely from a Local Display Unit (LDU200).

In the following graphs, the term, *shut-off leakage*, refers to the expected airflow through the valve in the shut-off position. The term, *casing leakage*, refers to the expected airflow through the penetrations of the valve body.

Casing Leakage: Shut-off Valves (Options S and L)

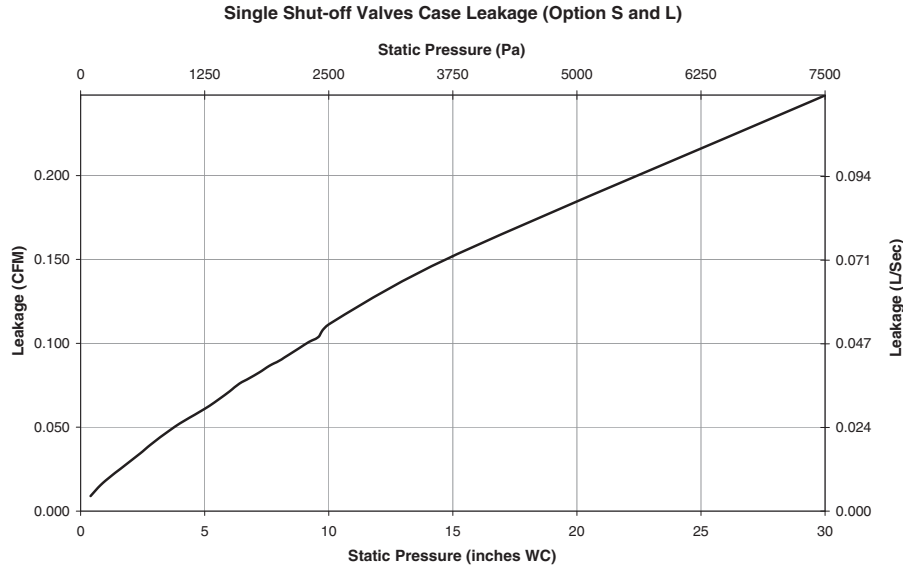

NOTE:

- Leakage rates shown in this graph are for all four valve sizes: 8-, 10-, 12-, and 14-inch. A 14-inch low leakage valve is not available at this time.
- Exceeds Eurovent Class A, B, C and D specifications (Eurovent Committee of Air Handling and Equipment Manufacturers) when valve duct surface areas noted in <Table (this page) are taken into account.
- Option S leakage rates are for all four valve sizes (8", 10", 12", 14").
- Option L leakage rates are for 8-, 10-, and 12-inch valves only. A 14-inch low-leakage valve is not available at this time.

Calculating Valve Area

To calculate leakage areas that take into account valve and duct area, use the Casing Leakage graph above and this table. Select the valve leakage at the appropriate design pressure and the related valve area from the table. For example:

$$\text{Leakage Specification} = \text{Leakage/Valve Area} = 0.150 \text{ CFM}/3.60 \text{ ft}^2 = 0.42 \text{ CFM per ft}^2$$

Valve Area Specifications:

Valve Size	Area (ft ²)	Area (m ²)
8-inch	3.60	0.33
10-inch	4.26	0.40
12-inch	6.28	0.58
14-inch	8.52	0.79

Shut-off Leakage: Standard Shut-off Valve (Option S)

Leakage rates shown in this graph (Option S) are for all four valve sizes: 8-, 10-, 12-, and 14-inch.

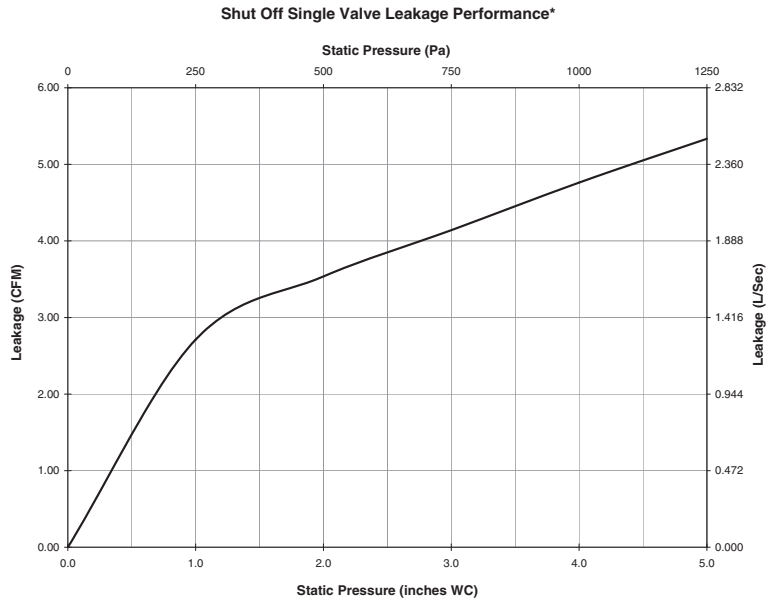

Shut-off Leakage: Low Leakage Shut-off Valve (Option L)

**Low Leakage Shut-off Valve (Option L)
Single Valve Shut-off Leakage**

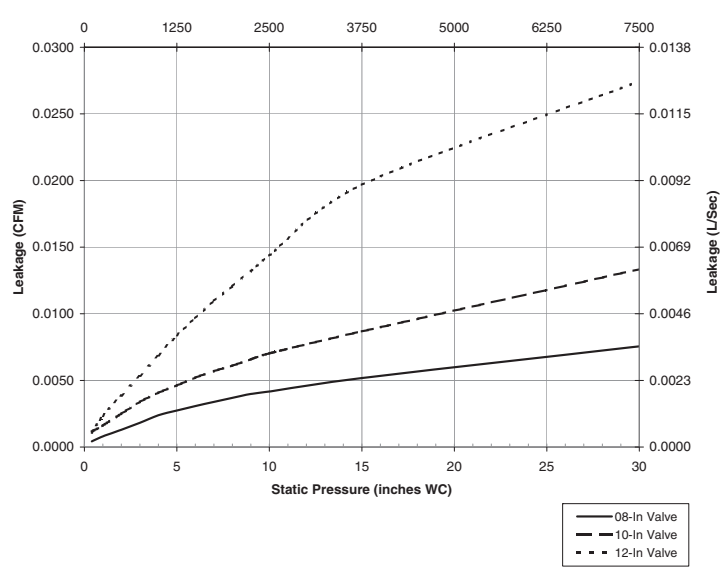

Recommended Valve Construction for Decontamination

Gaseous Decontamination Agent	Recommended Valve Construction
Hydrogen peroxide vapor	A
Ethylene oxide	B
Ammonium chloride	A
Chlorine dioxide	A**
Paraformaldehyde	A

NOTE:

- See Model Numbering Fields, Valve Construction in this section for details about these construction codes.
- Chemical resistance data acquired from Compass Corrosion Guide.
- **For concentrations up to 800 ppm. To achieve higher concentrations during decontamination, use construction B valves.

Traccel-TP Main Valve

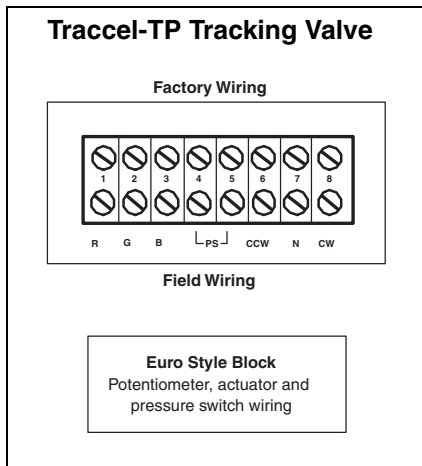
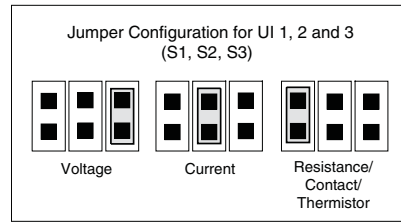
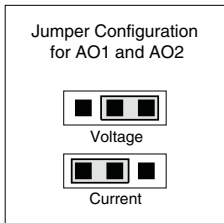
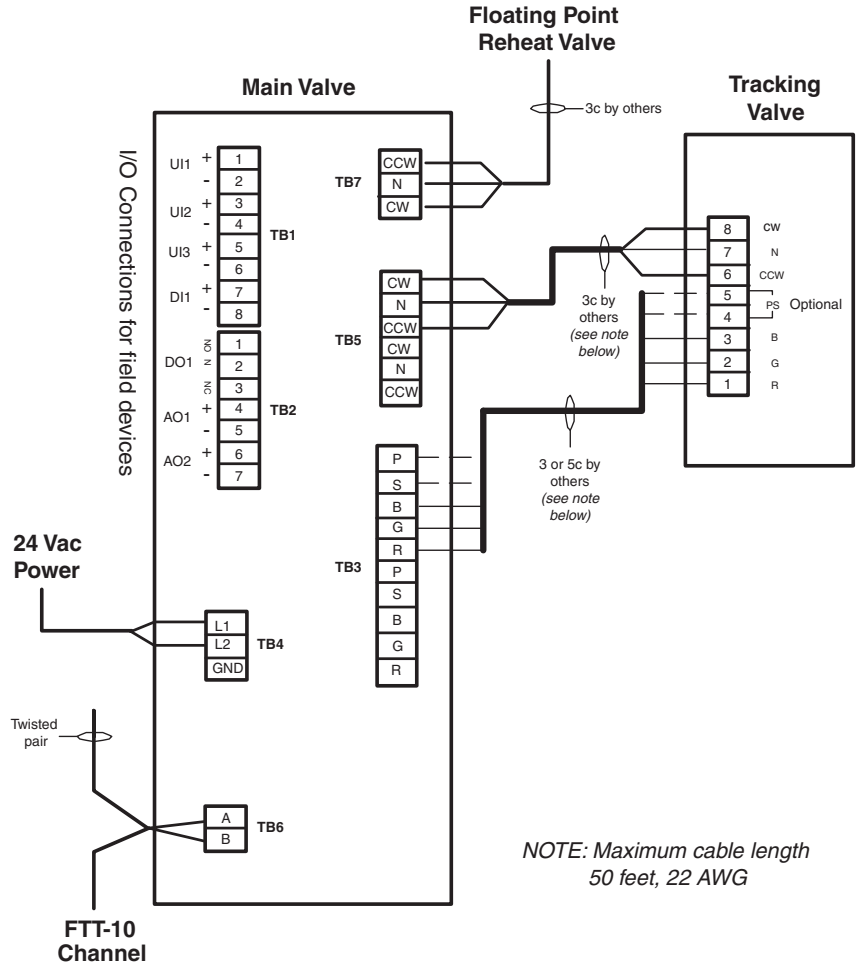
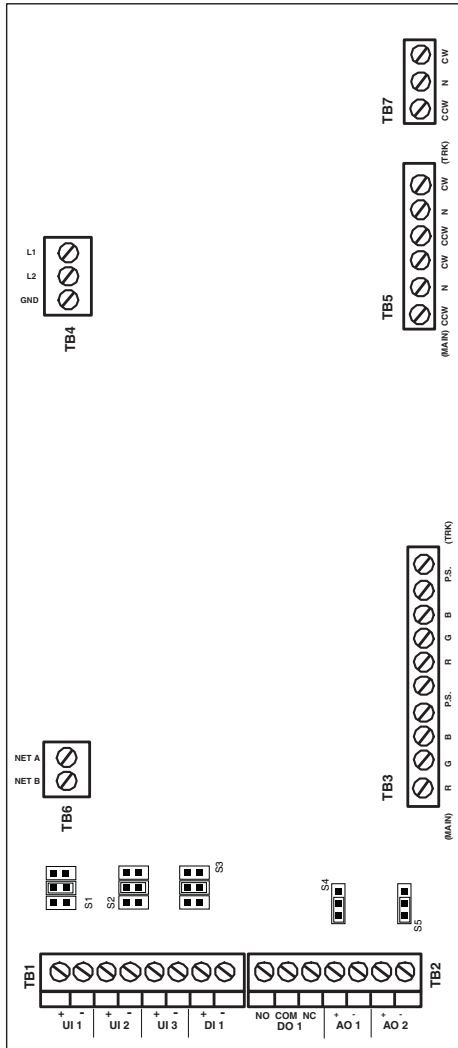

TERMINAL BLOCKS

Terminal Block	Typical Function	No. of Terminations
TB1	Input connections	8
TB2	Output connections	7
TB3	Main and tracking valve pot and pressure switch	10
TB4	Power (24 Vac input)	3
TB5	Main and tracking low-speed electric actuators	6
TB6	Communication (FTT-10)	2
TB7	Floating point actuator on reheat valve	3

Traccel-TX Main Valve

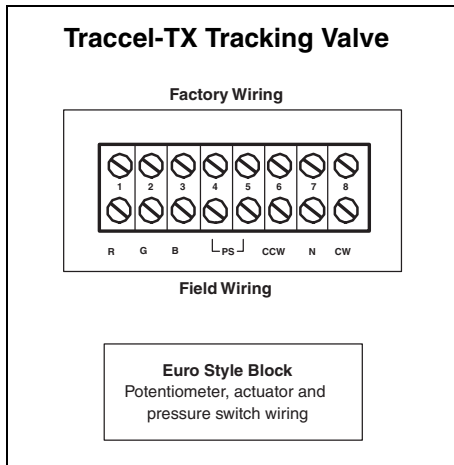
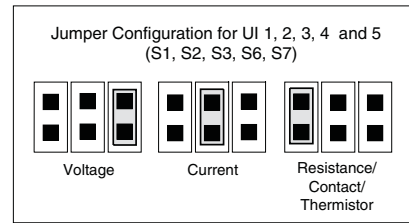
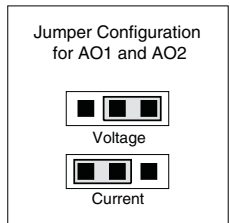
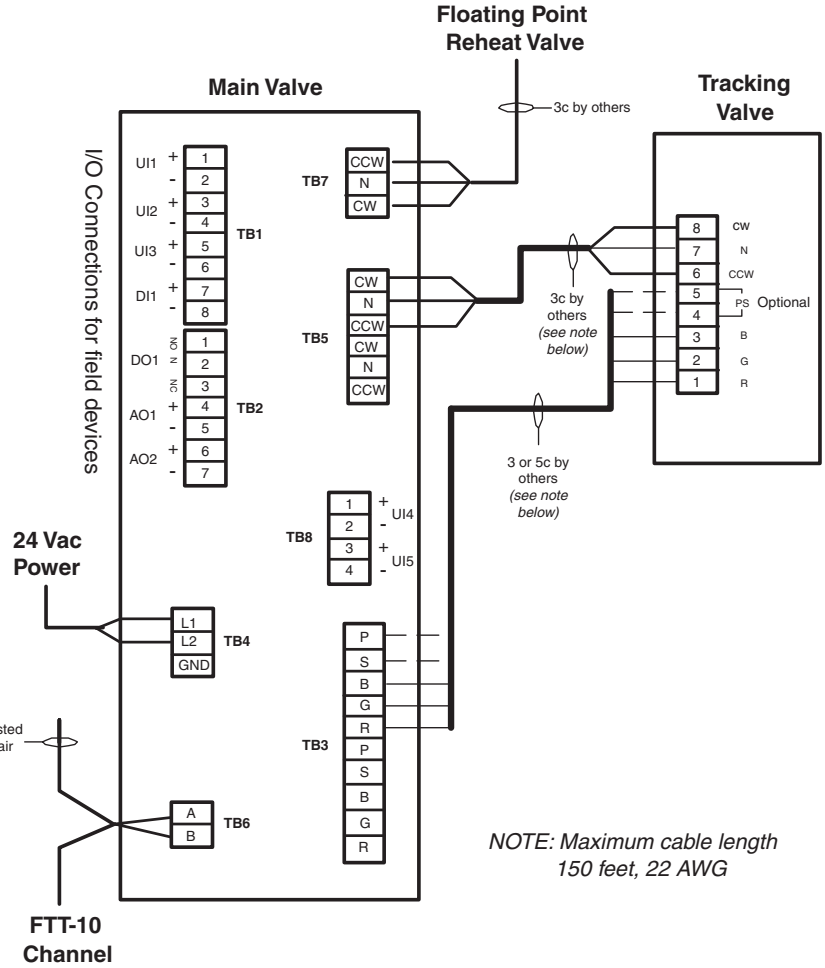
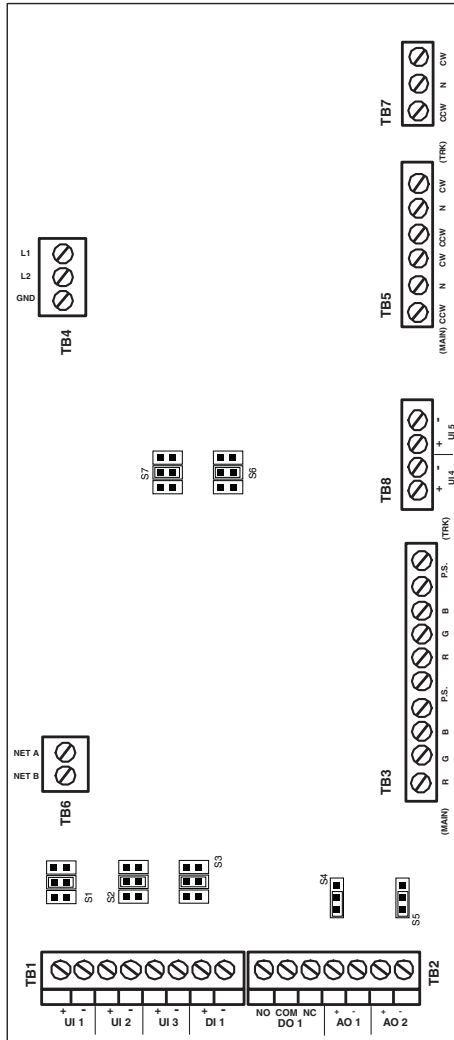

TERMINAL BLOCKS

Terminal Block	Typical Function	No. of Terminations
TB1	Input connections	8
TB2	Output connections	7
TB3	Main and tracking valve pot and pressure switch	10
TB4	Power (24 Vac input)	3
TB5	Main and tracking low-speed electric actuators	6
TB6	Communication (FTT-10)	2
TB7	Floating point actuator on reheat valve	3
TB8	Additional input connections	4

Traccel-SO Main Valve

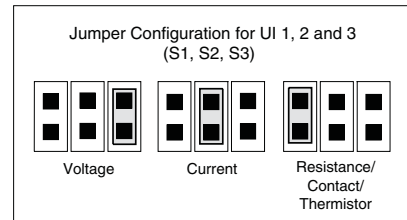
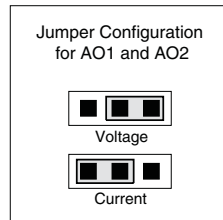
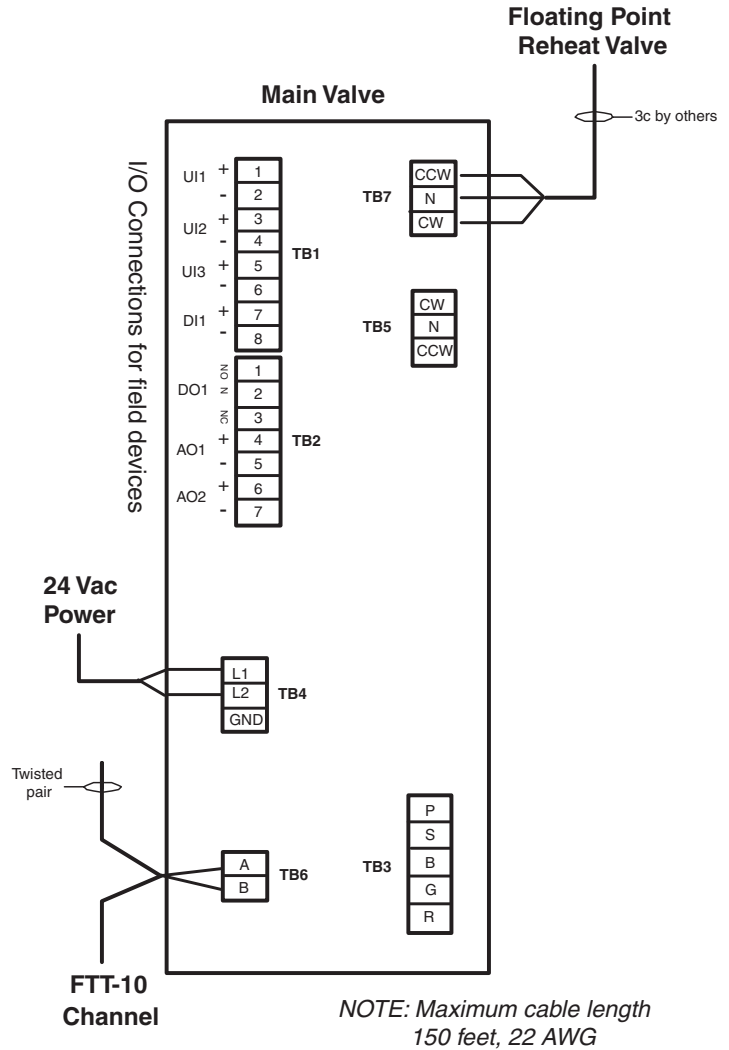
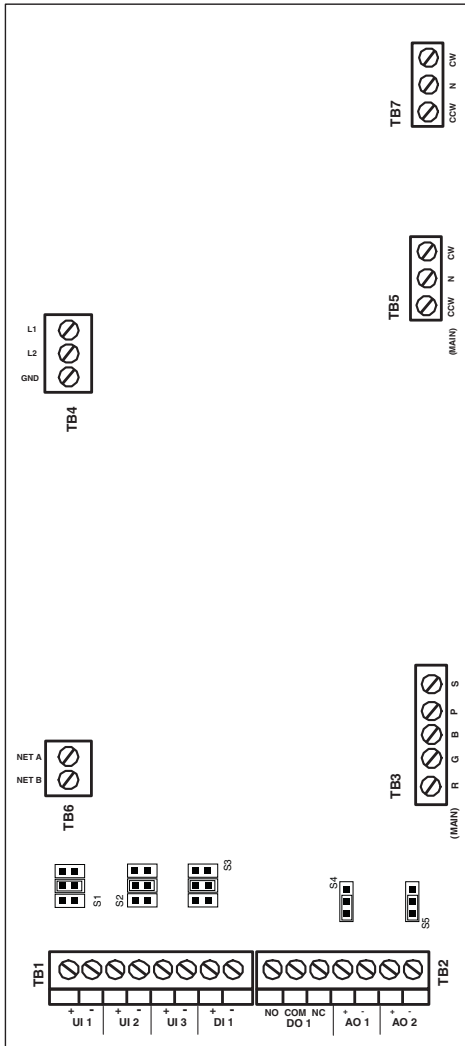

TERMINAL BLOCKS

Terminal Block	Typical Function	No. of Terminations
TB1	Input connections	8
TB2	Output connections	7
TB3	Main and tracking valve pot and pressure switch	5
TB4	Power (24 Vac input)	3
TB5	Main and tracking low-speed electric actuators	3
TB6	Communication (FTT-10)	2
TB7	Floating point actuator on reheat valve	3

Transformers

The Traccel Valve Controller requires the use of a step-down transformer (either 120/24 volt or 240/24 volt). Any transformer used to power these valve controllers must meet the requirements of an NEC Class 2 circuit.

- The secondary transformer must be limited to a maximum of 30 Vac.
- Secondary power shall be current limited with either internal circuit breaker protection or with a four-amp slow blow fuse, in accordance with NEC Class 2 power requirements.

Phoenix Controls offers the following recommendations; however, designers, installers and owners should always consult their national and local electrical codes before selecting transformers for their systems.

- Transformers should not exceed 100 VA. Use multiple transformers, rather than larger transformers, when more than 100 VA is required.
- Each pressurization zone should have either a dedicated single-phase primary circuit or a secondary circuit disconnect.
- If an earth ground is provided, it should not be connected to the valve controllers, even though there is a three-terminal connector on the control board.

NOTE: AC line voltage polarity must be maintained on all valve controllers and AC powered ancillary devices.

Transformer Sizing

To size a transformer, all of the VA loads for the circuit must be totaled. This table outlines the power ratings of Traccel products and related outside purchased equipment. Use these values to size the power transformers for the Traccel system.

Traccel Valve Controller		
Control type L (low-speed electric)	Single valve body	13 VA
	Dual valve body	17 VA
External Devices		
Router/repeater modules		2 VA
Sensor	Approved thermistor	0 VA
Heating valve	Belimo LM24 (2-state)	3 VA
Heating valve	Belimo LM24SR (propor)	4 VA
Each 4-20 mA device	Example: transducers	0.5 VA

Power Conductor Sizing

For low-speed valves in a bus configuration:

As a rule of thumb for loads up to 100 VA, use 18 AWG cable with a maximum length of 110 feet (33 meters) between the transformer and the last daisy-chained device.

For a more exact length per load number, refer to this chart.

Maximum wire length (in feet) given a wire gauge and VA delivery by transformer					
VA Delivered	Wire Gauge				
	14 AWG	16 AWG	18 AWG	20 AWG	22 AWG
10	2880	1743	1095	695	433
20	1440	871	548	347	216
30	960	580	365	213	144
40	720	435	274	174	108
50	576	348	219	139	86
60	480	290	182	115	72
70	411	249	156	99	61
80	360	217	136	86	54
90	320	193	121	77	48

Network Wiring

Room-level Network

Echelon Corporation has tested and approved 5 cables types for use with the FTT10 communications transceiver. Based on availability, cost and maximum distance limitations, we have focused our recommendation on two cable types:

- Generic NEMA level 4 cable, 22 AWG (0.65 mm) (see note below)
- Belden 8471 16 AWG (1.3 mm) cable, (or equivalent)

NOTE: Level 4 cable specified by Echelon as originally defined by the NEMA differs from the Category 4 specification proposed by the Electronic Industries Association/Telecommunication Industry Association (EIA/TIA).

The cables Phoenix Controls recommends are two-conductor, twisted-pair (TP) without a shield. A shield, or drain wire, is not required for Traccel communications wiring and should not be used. Both of these cables are available from multiple sources either solid or stranded, in plenum and non-plenum rated versions.

- If two conductors are to be placed in a terminal opening, twist the bare conductors prior to inserting these in the terminal opening.
- If a wall-mounted sensor with a communications jack is used, the connections to the jack must be treated as either a bus connection or an EOL connection.
- While the room-level communications wiring is not polarity sensitive, it is recommended that a consistent color-coding and polarity convention be followed.
- Each terminal on the terminal block will accommodate up to two 16 AWG (1.3 mm) stranded conductors.
- Communications connections are to be made following a bus or daisy chain topology.
- Two end-of-line (EOL) terminators must be installed, one at each end of the room-level network.

Maximum Cable Lengths

- When using Level 4 cable operating in a bus topology, the maximum cable length is 4500 feet (1370 meters).
- When using 16 AWG cable operating in a bus topology, the maximum cable length is 8800 feet (2680 meters).

Phoenix Controls Wiring Recommendations

- Use cables recommended by Phoenix Controls.
- Stranded wire is strongly recommended for ease of installation.
- Follow good wiring practices:
 - Do not run the communications cable in the same conduit or wire way as the power cables.
 - If the communications cables must cross power cables, it is best to do so at a 90-degree angle.
 - Shield or drain wires, if present, should be wrapped with insulating tape to prevent contact with exposed conductors or contacts.
 - Maintain a consistent color code or polarity all the way through the wiring system.
 - All connections must meet the requirements of an NEC Class 2 circuit.
 - Local and national electrical codes take precedence.

POINTS

The two tables in this section contain points available for integration in a building management system (BMS). Table 1 is a list of points for open LON integration and Table 2 is a list of points for integration through the Phoenix Controls family of servers.

Table 1. Points for Open LON Integration

Description	Object Type	Object Name	Network Variable Type (SNVT)	Network Variable (NV) Name
Space temperature sensor input	8502	SCC VAV	SNVT_temp_p	nviSpaceTemp
Occupied temperature set point input	8502	SCC VAV	SNVT_temp_p	nviTempSetpt
Occupied override input	8502	SCC VAV	SNVT_occupancy	nviOccOverride
Occupancy sensor override	8502	SCC VAV	SNVT_occupancy	nviOccSensor
Application mode command input	8502	SCC VAV	SNVT_hvac_mode	nviApplicMode
Unoccupied cooling temperature set point	8502	SCC VAV	SNVT_temp_p	nviUnoccCoolStpt
Unoccupied heating temperature set point	8502	SCC VAV	SNVT_temp_p	nviUnoccHeatStpt
Auxiliary temperature set point input	8502	SCC VAV	SNVT_temp_p	nviAuxTempSetpt
Local temperature set point lever enable/scaling input	8502	SCC VAV	SNVT_switch	nviLclLeverEbl
Space relative humidity sensor input <i>(TX Only)</i>	8502	SCC VAV	SNVT_lev_percent	nviSpaceRH
Space relative humidity set point input <i>(TX Only)</i>	8502	SCC VAV	SNVT_lev_percent	nviRHSetpt
Effective space temperature output	8502	SCC VAV	SNVT_temp_p	nvoSpaceTemp
Unit HVAC status output	8502	SCC VAV	SNVT_hvac_status	nvoUnitStatus
Effective space temperature set point output	8502	SCC VAV	SNVT_temp_p	nvoEffTempSetpt
Effective occupancy mode status output	8502	SCC VAV	SNVT_occupancy	nvoEffOccMode
Discharge air temperature output	8502	SCC VAV	SNVT_temp_p	nvoDischAirTemp
Terminal load output	8502	SCC VAV	SNVT_lev_percent	nvoTerminalLoad
Auxiliary temperature control loop command output	8502	SCC VAV	SNVT_switch	nvoAuxTempCmd
Effective space relative humidity output	8502	SCC VAV	SNVT_lev_percent	nvoSpaceRH
Effective space relative humidity set point output	8502	SCC VAV	SNVT_lev_percent	nvoEffRHSetpt
Space humidity control command output	8502	SCC VAV	SNVT_lev_percent	nvoRHCtrlCmd
BMS zone flow offset set point input	20033	SCC VAV FLOW	SNVT_flow_f	nviFlowOffsetCmd
BMS minimum supply flow set point input	20033	SCC VAV FLOW	SNT_flow	nviMinSupFlowCmd
BMS HVAC flow override command input	20033	SCC VAV FLOW	SNVT_hvac_overid	nviFlowOverride
BMS HVAC emergency override input	20033	SCC VAV FLOW	SNVT_hvac_emerg	nviHvacEmergCmd
IAQ command input	20033	SCC VAV FLOW	SNVT_lev_percent	nviIAQCmd
Additional flow #1 input	20033	SCC VAV FLOW	SNVT_flow	nviFlow_1
Additional flow #2 input	20033	SCC VAV FLOW	SNVT_flow	nviFlow_2
Zone total supply flow output	20033	SCC VAV FLOW	SNVT_flow	nvoTotalSupFlow
Zone total exhaust flow output	20033	SCC VAV FLOW	SNVT_flow	nvoTotalExhFlow
Zone volumetric offset feedback output	20033	SCC VAV FLOW	SNVT_flow_f	nvoFlowOffset
Effective zone volumetric offset set point output	20033	SCC VAV FLOW	SNVT_flow_f	svoEffFlwOffstSP
Supply valve flow feedback output	20033	SCC VAV FLOW	SNVT_flow	nvoMainValveFlow
Exhaust valve flow feedback output	20033	SCC VAV FLOW	SNVT_flow	nvoTrkValveFlow
Effective supply valve flow set point output	20033	SCC VAV FLOW	SNVT_flow	nvoEffMainFlowSP
Effective exhaust valve flow set point output	20033	SCC VAV FLOW	SNVT_flow	nvoEffTrkFlowSP
Space relative pressure output	20033	SCC VAV FLOW	SNVT_press_p	nvoPressure
BMS AO port 1 override input	20034	TrcDevice	SNVT_switch	nviAOCmd_1
BMS AO port 2 override input	20034	TrcDevice	SNVT_switch	nviAOCmd_2
BMS DO port override input	20034	TrcDevice	SNVT_switch	nviDOCmd
BMS floating point drive override input	20034	TrcDevice	SNVT_switch	nviFloatDriveCmd
Current alarm status of all alarm bits output	20034	TrcDevice	SNVT_state_64	nvoAlarmState
Universal input port 1 feedback output	20034	TrcDevice	SNVT_count_inc	nvoUI_1
Universal input port 2 feedback output	20034	TrcDevice	SNVT_count_inc	nvoUI_2
Universal input port 3 feedback output	20034	TrcDevice	SNVT_count_inc	nvoUI_3

Table 1. Points for Open LON Integration (Continued)

Description	Object Type	Object Name	Network Variable Type (SNVT)	Network Variable (NV) Name
Universal input port 4 feedback output	20034	TrcDevice	SNVT_count_inc	nvoUI_4
Universal input port 5 feedback output	20034	TrcDevice	SNVT_count_inc	nvoUI_5
Digital input port feedback output	20034	TrcDevice	SNVT_count_inc	nvoDI

POINTS (CONTINUED)

Table 2. Points for Integration through the Tracel Family of Servers

Description	Network Variable Type (SNVT/UNVT)	Network Variable (NV) Name	Field Name
Occupied temperature set point input	SNVT_temp_p	nviTempSetpt	nviTempSetpt
Occupancy override input	SNVT_occupancy	nviOccOverride	nviOccOverride
Application mode command input	SNVT_hvac_mode	nviApplicMode	nviApplicMode
Unoccupied cooling temperature set point	SNVT_temp_p	nviUnoccCoolStpt	nviUnoccCoolStpt
Unoccupied heating temperature set point	SNVT_temp_p	nviUnoccHeatStpt	nviUnoccHeatStpt
Auxiliary temperature set point input	SNVT_temp_p	nviAuxTempSetpt	nviAuxTempSetpt
Local temperature set point lever scaling input	SNVT_switch.value	nviLclLeverEbl	value
Local temperature set point lever enable input	SNVT_switch.state	nviLclLeverEbl	state
Space relative humidity set point input (TX Only)	SNVT_lev_percent	nviRHSetpt	nviRHSetpt
Effective space temperature output	SNVT_temp_p	nvoSccData	SpaceTemp
Phoenix temperature mode status output	PHX_TEMP_MODE	nvoSccData	PccTempMode
HVAC mode status output	SNVT_hvac_mode	nvoSccData	HvacTempMode
Effective space temperature set point output	SNVT_temp_p	nvoSccData	EffSpaceTempSP
Effective auxiliary temperature set point output	SNVT_temp_p	nvoSccData	EffAuxTempSP
Effective occupancy mode status output	SNVT_temp_p	nvoTpFlowData	EffOccMode
Discharge air temperature output	SNVT_temp_p	nvoSccData	DschrgAirTemp
Exhaust air temperature output	SNVT_lev_percent	nvoSccData	ExhaustAirTemp
Primary temperature loop cooling command output	SNVT_lev_percent	nvoSccData	PrimaryCoolCmd
Primary temperature loop heating command output	SNVT_lev_percent	nvoSccData	PrimaryHeatCmd
Auxiliary temperature control loop command output	SNVT_switch.value	nvoSccData	AuxTempCmd.value
Auxiliary temperature control loop status (ON/OFF)	SNVT_switch.state	nvoSccData	AuxTempCmd.state
Effective space relative humidity output (TX Only)	SNVT_lev_percent	nvoSccData	SpaceRH
Effective space relative humidity set point output (TX Only)	SNVT_lev_percent	nvoSccData	EffSpaceRHSetpt
Space humidity control command output (TX Only)	SNVT_lev_percent	nvoSccData	HumidifyCmd
Space dehumidify control command output (TX Only)	SNVT_lev_percent	nvoSccData	DehumidifyCmd
BMS zone flow offset set point input	SNVT_flow_f	nviFlowOffsetCmd	nviFlowOffsetCmd
BMS minimum supply flow set point input	SNT_flow	nviMinSupFlowCmd	nviMinSupFlowCmd
BMS HVAC flow override command input	SNVT_hvac_overid	nviFlowOverride	nviFlowOverride
BMS HVAC emergency override input	SNVT_hvac_emerg	nviHvacEmergCmd	nviHvacEmergCmd
IAQ command input	SNVT_lev_percent	nviIAQCmd	nviIAQCmd
Zone total supply flow output	SNVT_flow	nvoTPFlowData	uwTotalSup
Zone total exhaust flow output	SNVT_flow	nvoTPFlowData	uwTotalExh
Zone volumetric offset feedback output	SNVT_flow_f	nvoTPFlowData	swFlowOffset
Effective zone volumetric offset set point output	SNVT_flow_f	nvoTPFlowData	swEffFlowOffsetCmd
Supply valve flow feedback output	SNVT_flow	nvoTPFlowData	uwMainFlow
Exhaust valve flow feedback output	SNVT_flow	nvoTPFlowData	uwTrackFlow
Effective supply valve flow set point output	SNVT_flow	nvoTPFlowData	uwEffMainFlowSP
Effective exhaust valve flow set point output	SNVT_flow	nvoTPFlowData	uwEffTrackFlowSP
Space relative pressure output (TX Only)	SNVT_press_p	nvoPressure	nvoPressure
BMS AO port 1 override command value input	SNVT_switch.value	nviAOCmd_1	value
BMS AO port 1 override command state input	SNVT_switch.state	nviAOCmd_1	state
BMS AO port 2 override command value input	SNVT_switch.value	nviAOCmd_2	value
BMS AO port 2 override command state input	SNVT_switch.state	nviAOCmd_2	state
BMS DO port override command value input	SNVT_switch.value	nviDOCmd	value
BMS DO port override command state input	SNVT_switch.state	nviDOCmd	state
BMS floating point drive override command value input	SNVT_switch.value	nviFloatDriveCmd	value
BMS floating point drive override command state input	SNVT_switch.state	nviFloatDriveCmd	state
Supply valve jam alarm output	SNVT_state_64	nvoAlarmState	JamAlarm
Supply valve flow alarm output	SNVT_state_64	nvoAlarmState	FlowAlarm

Table 2. Points for Integration through the Traccel Family of Servers (Continued)

Description	Network Variable Type (SNVT/UNVT)	Network Variable (NV) Name	Field Name
Exhaust valve jam alarm output	SNVT_state_64	nvoAlarmState	JamAlarm2
Exhaust valve flow alarm output	SNVT_state_64	nvoAlarmState	FlowAlarm2
Universal input port 1 feedback output	SNVT_count_inc	nvoUI_1	nvoUI_1
Universal input port 2 feedback output	SNVT_count_inc	nvoUI_2	nvoUI_2
Universal input port 3 feedback output	SNVT_count_inc	nvoUI_3	nvoUI_3
Universal input port 4 feedback output <i>(TX Only)</i>	SNVT_count_inc	nvoUI_4	nvoUI_4
Universal input port 5 feedback output <i>(TX Only)</i>	SNVT_count_inc	nvoUI_5	nvoUI_5
Digital input port feedback output	SNVT_switch	nvoDI	nvoDI
Phoenix emergency mode command input	UNVT_Emergency	nviPccEmergCmd	nviPccEmergCmd
Effective Phoenix emergency mode status output	UNVT_Emergency	nvoTpFlowData	EffPccEmergMode
Effective HVAC emergency mode status output	SNVT_hvac_emerg	nvoTpFlowData	EffHvacEmergMode

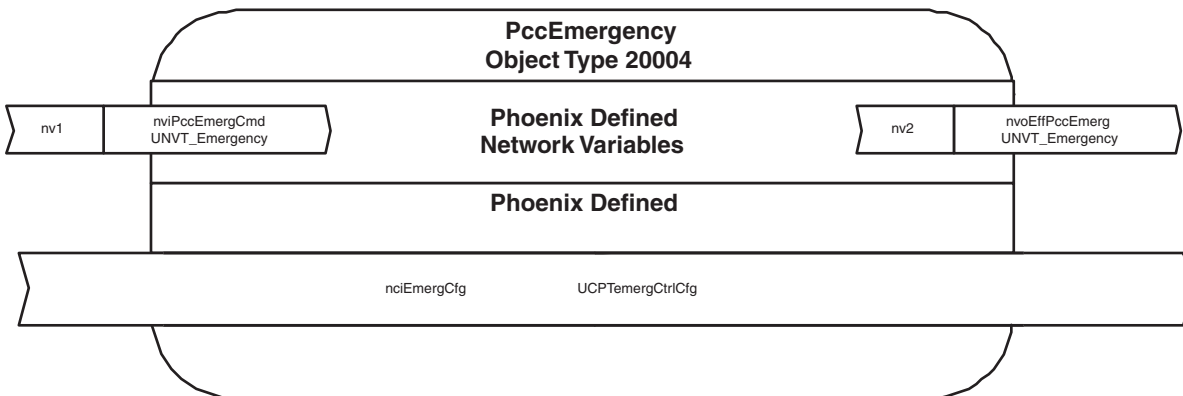
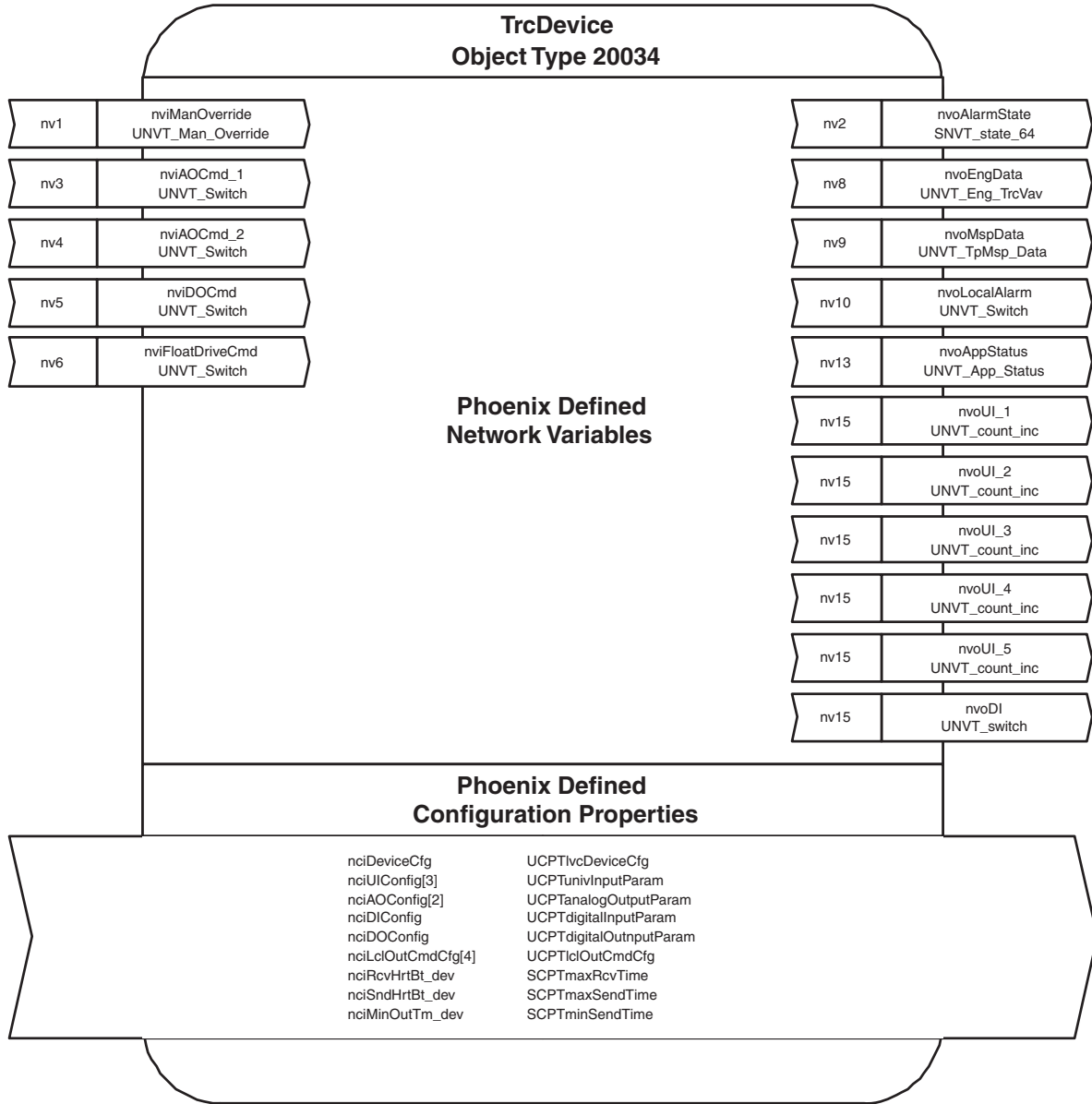

LONMARK® OBJECTS & NETWORK VARIABLES (CONTINUED)

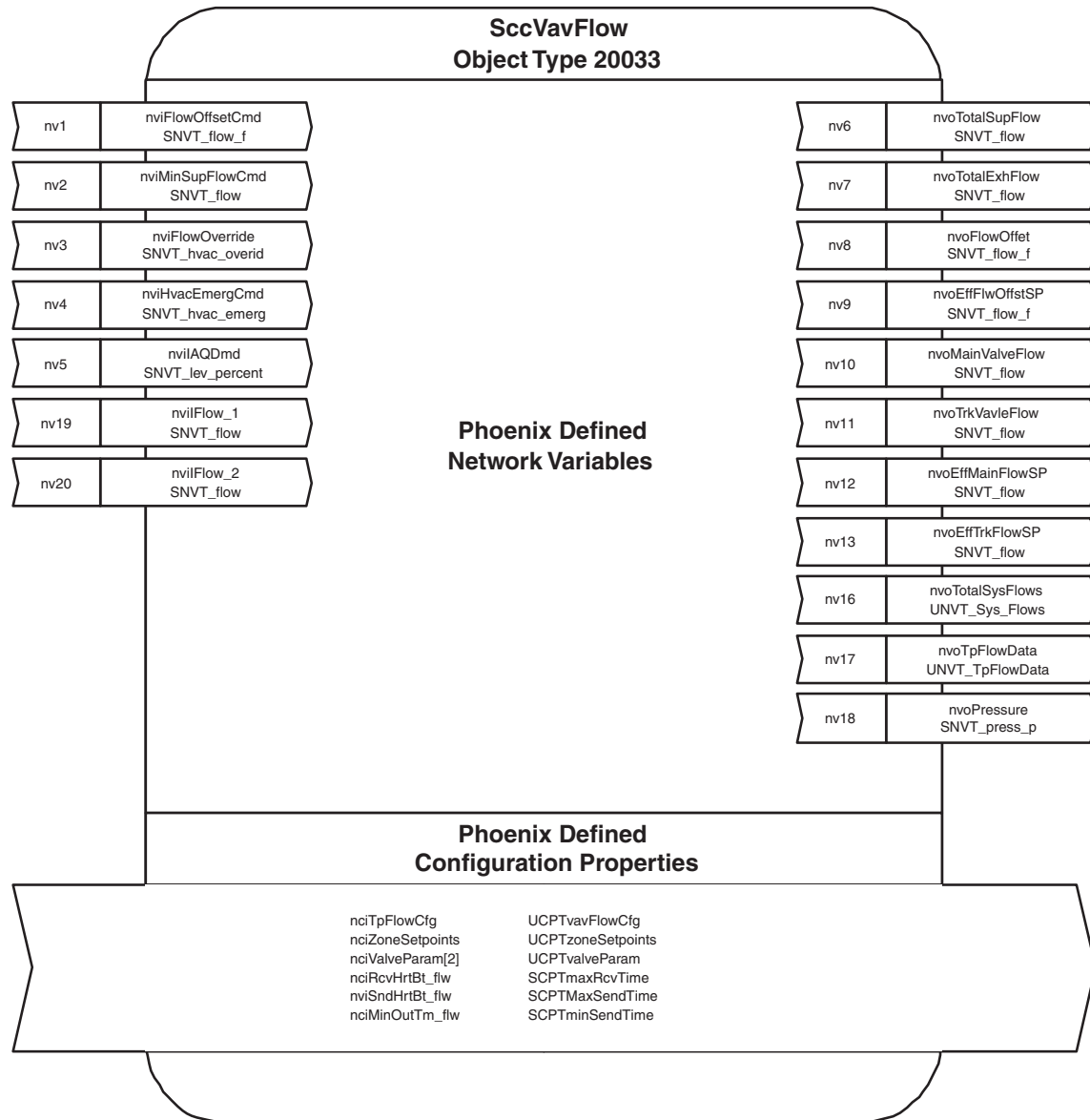

MAINTENANCE

Traccel valves require no ongoing preventive maintenance. Once the field engineer has completed the field startup, the valves will provide years of continuous operation.