

The Phoenix Controls PTS102 Duct Mounted Temperature Sensors provide a standard 10K-2 thermistor output or, with the TV option, a scaled temperature 0-10 Vdc analog output. The PTS102 features medical-grade closed cell foam to seal the probe insertion hole and to absorb vibration. Mounting tabs allow for easy installation directly to the wall of the duct. The PTS102 has etched Teflon[®] leadwires and double encapsulated sensors to create a watertight package that can withstand high humidity and condensation and perform under a wide range of environmental conditions. The PTS102 have probe lengths from 4" to 18" to accommodate most duct shapes and sizes.

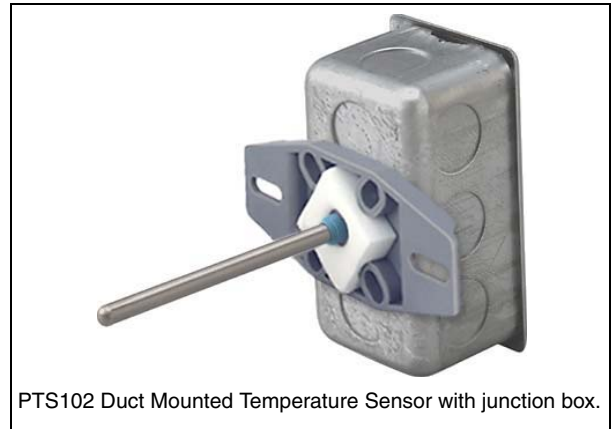

PTS102 Duct Mounted Temperature Sensor with junction box.

SPECIFICATION

Feature	TV Output Option	Standard Option
Power Supply:	13 to 35 Vdc	—
Temperature Transmitter:		
• Output	0 to 10 Vdc, 10K Ω minimum	—
• Range	35 °F To 180 °F (scalable)	—
• Accuracy	± 1.83 °F (1.015 °C)	—
• Linearity	$\pm .117$ °F (0.065 °C)	—
Sensor:	Thermistor, two-wire resistive	Thermistor, two-wire resistive
• Ro trim	10 K Ω @25°C, NTC	—
• Accuracy	± 0.36 °F (± 0.2 °C/year)	± 0.2 °C (0 to 70 °C)
• Stability	<0.036 °F/year (<0.02 °C/year)	<0.02 °C/year
• Drift	<0.02 °C/year	<0.02 °C/year
• Dissipation	2.7 mW/°C	2.7 mW/°C
• Range	-67 °F to 221 °F (-55 °C to 105 °C)	-67 °F to 302 °F (-55 °C to 150 °C)
Response:	10 seconds at the 63% step	—
Probe:	0.25" stainless steel	0.25" stainless steel
Lead wire:	5 wires, 6' long	As Ordered
Insulation:	22 AWG Etched teflon (plenum rated)	—
Duct Mounting:	Handy box with tab bracket	As Ordered
Enclosure Types:	Electrical 2" x 4" handy box	As Ordered
Enclosure Ratings:	NEMA 1, UL94H-B	As Ordered
Enclosure Material:	Galvanized steel	As Ordered
Ambient:	0 to 95% RH, Non-condensing -40 °F to 185 °F (-40°C to 85 °C)	0 to 100% RH, Non-condensing -40 °F to 212 °F (-40°C to 100 °C)
Agency:	RoHS, NEMA 1	As Ordered

FEATURES

- Mounting tabs for easy installation
- Probe lengths: 4" to 18"
- Series 304 stainless steel probes
- Double encapsulated sensors
- Medical-grade foam padding
- Etched Teflon[®] leadwires
- Range:
35 °F To 180 °F (scalable) - TV option only
-40 °F to 221 °F - Standard

ORDERING GUIDE

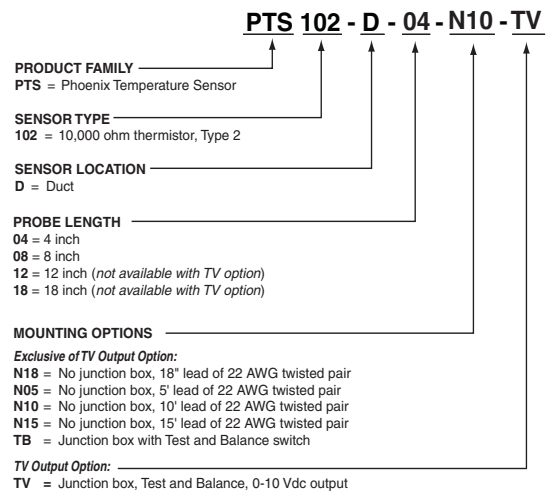
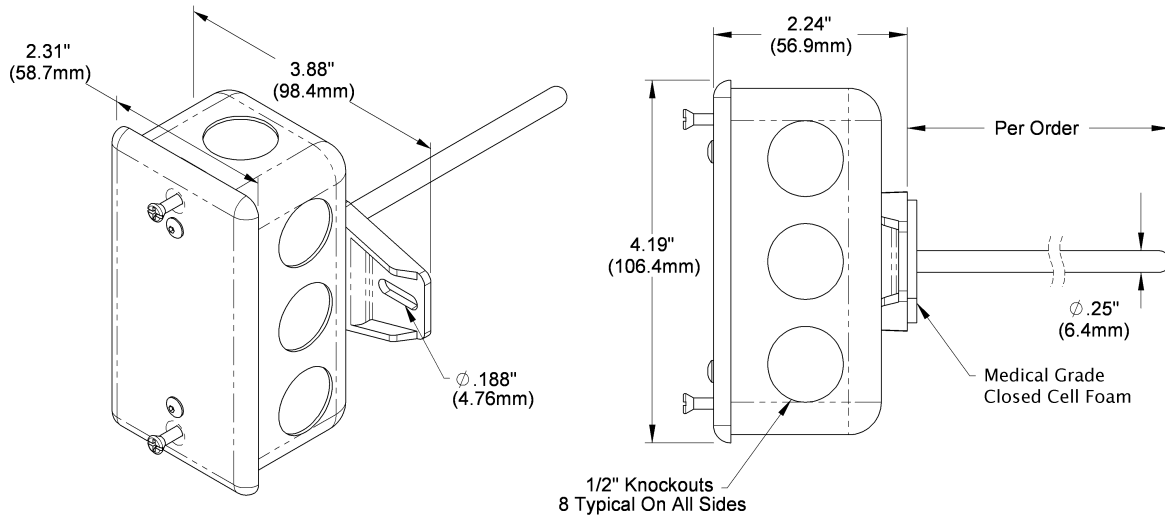

TABLE OF CONTENTS

Dimensions	2
Installation	2
Wiring and Termination	3
Troubleshooting	3

DIMENSIONS

NOTE: Junction box provided only with TB and TV options.



INSTALLATION (ALL MODELS)

1. Place the sensor in the middle of the duct away from temperature stratified air, coils or humidifiers to achieve the best temperature reading.

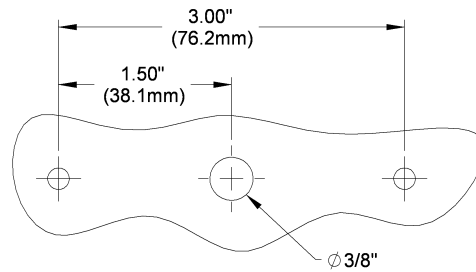

2. Drill the probe hole as depicted below for the enclosure being used. Insert the probe into the duct.

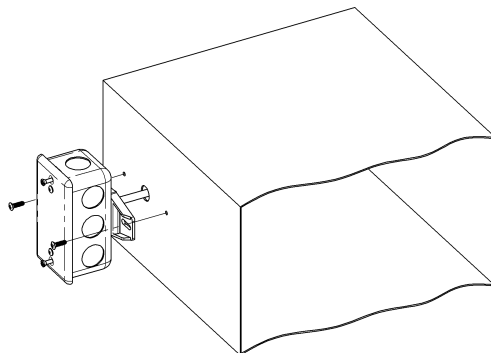

3. Mount the enclosure to the duct using #8 screws through a minimum of two opposing mounting tabs provided. A 1/8 inch pilot screw hole in the duct makes mounting easier through the mounting tabs. Use the enclosure tabs to mark the pilot hole locations.
4. Snug up the sensors so that the foam backing is depressed to prevent air leakage but do not over-tighten or strip the screw threads.

WIRING AND TERMINATION (TV OUTPUT OPTION ONLY)

Phoenix Controls recommends using twisted pair of at least 22 AWG and sealant filled crimp type connectors for all wire connections and sealant filled crimp twist-on wire nuts. We also recommend that wiring **NOT** be run in the same conduit as the line voltage wiring or with wiring used to supply highly inductive loads such as motors, generators and coils.

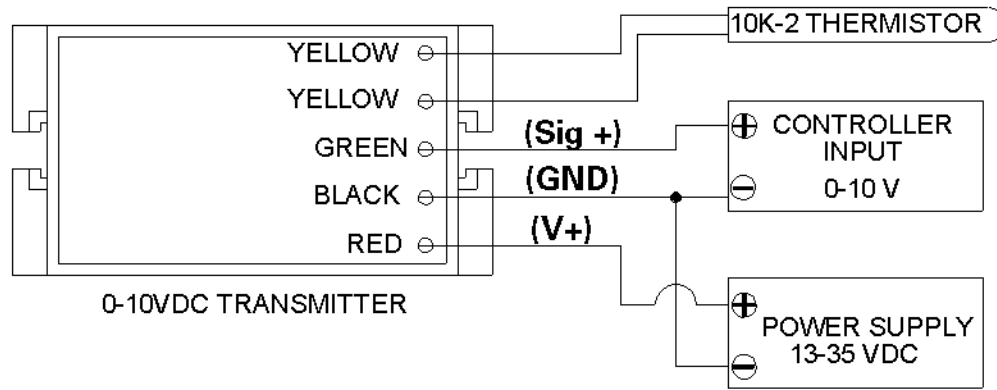

TROUBLESHOOTING (TV OUTPUT OPTION ONLY)

$$\frac{(\text{Sig}+) \times (\text{Tspan})}{10} + T_{\text{Low}} = T$$

Sig+ = Voltmeter reading in volts

T_{span} = # of Degrees in Temp Span (for example, 180 - 35 = 145)

T_{Low} = Low end to the Temp Span (for example, 35)

T = Temperature at the sensor

1. Measure the voltage by placing a voltmeter (V) across the transmitter's (+) and (-) terminals. This voltage should be between 13 to 35 Vdc.
2. Measure the voltage by placing a voltmeter across the sig(+) and (-) terminal. The voltage should read according to the equation above to get the temperature.
3. The temperature surrounding the transmitter must be between -40 and 185 °F (-40 and 85 °C) for the standard ruggedized configurations.

NOTE: The temperature at the temperature sensor's location using an accurate temperature standard. Disconnect the temperature sensor wires and measure the temperature sensor's resistance with an ohmmeter. Compare the temperature sensor's resistance to an appropriate sensor table. If the measured resistance is different from the temperature table by more than 5%, call Phoenix Controls for technical support.