

**APPLICATIONS**

**Airflow Volume Control**

Medium pressure Phoenix Controls Accel® II Venturi Valves combine a mechanical pressure-independent regulator with a high-speed position/airflow controller. Analog-based valve controllers provide the conventional control solution for critical environments and are available with either pneumatic or high-speed electric actuation. All valve types include an immediate response mechanical assembly to maintain the airflow set point as duct static pressure varies.

Analog valves are typically used in Variable Air Volume (VAV) standalone and point-to-point BMS integrated systems; using analog circuitry with 0-10 Vdc input and output signals. Associated analog valves are used as booster valves, receiving a command signal from an analog main valve. Common applications are laboratory airflow control for fume hoods, general exhaust, room supply air, and miscellaneous ancillary exhausts (canopies, snorkels, biosafety cabinets, etc.).

For VAV valves, a precision potentiometer is attached to the pivot arm and each valve is ramped through its entire flow range at a fixed static pressure and a characterization curve of resistance versus flow is captured and downloaded to the valve mounted controller. The valve mounted controller precisely measures and controls the shaft position through a variety of actuation options and develops a precise flow feedback value. The known relationship of pivot arm position to flow allows the controller to rapidly drive the cone and shaft a specific orifice opening with little or no overshoot.

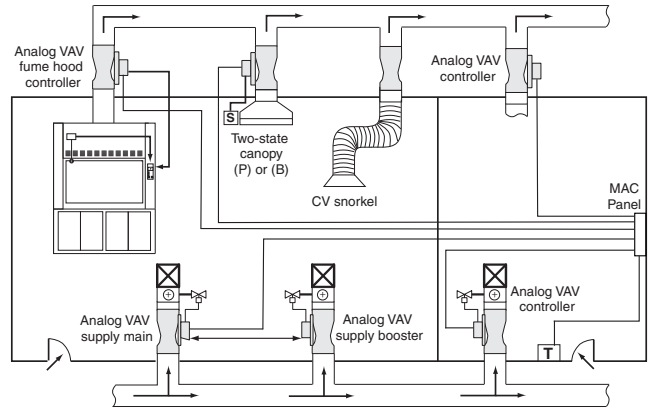

**SPECIFICATIONS**

**Construction**

- 16 ga. spun aluminum valve body with continuous welded seam
- Valve bodies available as uncoated aluminum or with corrosion-resistant baked phenolic coatings
- Composite Teflon® shaft bearings
- Spring grade stainless steel spring and polyester or PPS slider assembly
- Supply valves insulated with 3/8" (9.5 mm) flexible closed-cell polymer-based foam. Flame/smoke rating 25/50. Density is 1.5 lb/ft³ (24.0 kg/m³).

**Operating Range**

- 32-122 °F (0-50 °C) ambient
- 10-90% non-condensing RH

**Sound**

Designed for low sound power levels to meet or exceed ASHRAE noise guidelines.

**Performance**

- Pressure independent over a 0.6"-3.0" WC (150-750 Pa) drop across valve
- Volume control accurate to ±5% of airflow command signal
- No additional straight duct runs needed before or after valve
- Available in flows from 35-6,000 CFM (60-10,000 m³/hr)
- Response time to change in command signal: <1 second
- Response time to change in duct static pressure: <1 second

**VAV Controller**

- Pneumatic Analog: ±15 Vdc, ±5% @ 0.145 amp
- Electric Analog: 24 Vac (±15%) @ 60 Hz
- Pneumatic and Electric Analog:
  - 0-10 Vdc command signal
  - 0-10 Vdc flow feedback signal
  - 0-10 Vdc alarm signal

**Actuation**

- Pneumatic Air Consumption:\*
  - 20 psi (-0/+2 psi) with a 20 micron filter main air required (except for CxV)
  - Compressor Sizing: Accel II Valves are not continuous air-consuming devices, yet for compressor sizing, use:
    - single and dual valves: 10 scim
    - triple and quad valves: 20 scim
- High Speed Electric Power Consumption:
  - Singles/Duals *per valve* (one controller/one actuator): 70 VA
  - Triples/Quads *per valve* (two controllers/two actuators): 140 VA
  - Notes:
    1. All power consumption VA ratings listed here are based on fully-loaded I/O.



Teflon is a registered trademark of DuPont Company.

**FEATURES**

FEATURE/OPTION	VAV (EXV/MAV) Pneumatic	VAV (EXV/MAV) Electric
Control type	A	E
Flow feedback signal	X	X
14-inch valve*	—	—
Fail Safe	NO/NC	NO/NC or Last Position
Factory-insulated valve body (supply)	X	X
Field-adjustable flow	X	X
Flow alarm via feedback circuit	X	X
Flow alarm via pressure switch	Option	Option
Low noise diffuser construction†	X	X

All valves include pressure-independent controller, factory-calibrated position controller, and are available in flows from 35-10,000 CFM (60-16,990 m³/hr).

†Accel II valves are designed to reduce sound over all frequencies, but significantly target the lower bands (125-500 Hz) to help eliminate the need for silencers.

\*Not offered in the 14" valve at this time.

**TABLE OF CONTENTS**

Ordering Guide ..... 2  
 Valve Controllers and Options ..... 3  
 Points and Wiring ..... 3

# ORDERING GUIDE

## MAV A 1 12 L - A E E H O - REI SFX

### VALVE FAMILY

EXV = Analog exhaust valve  
 MAV = Analog supply valve (comes standard with insulation)

### VALVE CONSTRUCTION

**A** = Body and cone uncoated aluminum; uncoated 316 stainless steel shaft  
**B** = Body and cone with baked phenolic coating, PFA-coated 316 stainless steel shaft  
**C** = Body, cone, and hardware with baked phenolic coating, PFA-coated 316 stainless steel shaft  
**D** = Body and cone with a PVDF-coating, hardware with baked on corrosion-resistant epoxy phenolic coating or PVDF-coating, and a PFA-coated 316 stainless steel shaft; only available for 8-, 10-, and 12-inch Design A single-body valves (no flanges)

### NUMBER OF VALVE BODIES

**F** = One valve body with a welded circular flange  
**1** = One valve body, no flange  
**2** = Two valve bodies (dual)  
**3** = Three valve bodies (triple)  
**4** = Four valve bodies (quad)

### SIZE

**08** = 8" valve (7.88"/200 mm actual diameter)  
**10** = 10" valve (9.67"/246 mm actual diameter)  
**12** = 12" valve (11.84"/301 mm actual diameter)

### FLOW/PRESSURE OPERATING RANGE

**M** = Medium pressure operation; pressure independent over a range of 0.6 to 3.0" WC (150 to 750 Pa), associated pressure switch trips at 0.3" WC  
 See *Standard Valve Flow/Pressure Operating Range* table below

### VALVE DESIGN

**A** = Conical shape diffuser (Accel II), this valve is not available as a shut-off valve

### VALVE OPTIONS

**EVI** = Exhaust valve with insulation blocks and insulation.  
**IBO** = Valve with insulation blocks only, no insulation  
**PSL** = Pressure switch, low limit (.3" WC) (see Notes 1, 2)  
**REI** = Remote electronics (indoor) (see Note 3)  
**REO** = Remote electronics (outdoor) for pneumatic actuators only (see Note 4)  
**WRE** = Weather-resistant electronics (outdoor) for electric actuation only (see Note 5)  
**SFB** = Square flanges mounted on both ends of single body valves  
**SFX** = Single square flange mounted on one end of a single body valve; inlet on exhaust valves or discharge on supply valves  
**SFM** = Scaling function module (available with Control Type E or M only)  
**VPO** = Power supply, valve-mounted, 120 Vac to +/- 15 Vdc (see Note 6)  
**VPT** = Power supply, valve-mounted, 230 Vac to +/- 15 Vdc (see Note 6)

### FAIL-SAFE POSITION

**C** = Normally closed  
**O** = Normally open  
**Z** = Not applicable (Control Type E Only)

### VALVE ORIENTATION

**H** = Horizontal  
**U** = Vertical upflow  
**D** = Vertical downflow

### VALVE CONTROLLER DESIGNATION

**E** = Electronic controller with no booster valves  
**H** = Hood exhaust valve with pressure switch  
**P** = Associated or standalone valve without pneumatic solenoids, for flow feedback function  
**S** = Associated or standalone analog valve without pneumatic solenoids  
**Q** = Hood exhaust valve with booster valves; includes H/I card with alarm relay output and pressure switch  
**R** = Hood exhaust valve with no booster valves; includes H/I card with alarm relay output and pressure switch  
**I** = Hood exhaust valve with booster valves; includes H/I card and pressure switch  
**M** = Main electronic valve with booster valves

### CONTROL TYPE

**A** = Pneumatic Analog  
**E** = High-speed Electric Analog

### STANDARD ANALOG VALVE FLOW/PRESSURE OPERATING RANGE

Designation	Size	Operating Range in CFM (m3/hr)				Pressure Drop Across Valve
		Single	Dual	Triple	Quad	
M = Medium pressure	08"	35-700 (60-1185)	—	—	—	0.6-3.0" wc (150-750 Pa)
	10"	50-1000 (85-1695)	100-2000 (170-3390)	—	—	
	12"	90-1500 (155-2545)	180-3000 (310-5090)	270-4500 (465-7635)	360-6000 (620-10,180)	

### NOTES:

- Analog hood booster valves with pneumatic actuators (Control Type = A) must have Controller Type P and a Pressure Switch (Valve Option = PSL).
- Analog hood booster valves with electric actuators (Control Type = E) must have Controller Type S and a Pressure Switch (Valve Option = PSL).
- Option REI: Remote Electronics *indoor installations* ONLY, the distance to the valve controller is limited to:
  - 75 feet of pneumatic tubing for pneumatic actuators (Control Type = A).
  - 40 inches (1 meter) of 18 gauge cable for high-speed electric actuators (Control Type = E).
- Option REO: Remote Electronics *outdoor installations* ONLY. Limited to pneumatically actuated valves (Control Type = A). Horizontal orientation only.
  - Includes sealed Vpot, small weather-resistant NEMA 3R box mounted on the base channel for others to connect Vpot cables, and a valve controller in an enclosure that has been disconnected from the base channel and shipped in the same box as the valve.
  - Maximum distance between remote mounted enclosure and valve is 75 feet (22.8 meters) - the maximum allowable length for pneumatic tubing.
  - REQUIRES use of a dog house enclosure provided by others to protect the valve from the elements and maintain temperature and humidity conditions within Phoenix Controls specifications.
- Option WRE: Weather Resistant Electronics, outdoor installations. Applies to ELECTRICALLY actuated valves with sufficient IP ratings (Control Type = E for single-body valves; Control Type = E for multi-body valves). HORIZONTAL orientation ONLY.
  - Includes sealed Vpot and large weather-resistant IP66 box mounted on the base channel that houses the controller and all connections to/from it.
  - When used in High-Speed Electric applications, standard actuators are sufficient (Control Type = E) since they are IP56 actuators.
  - REQUIRES use of a dog house enclosure, provided by others, to protect the valve from the elements and maintain temperature and humidity conditions within Phoenix Controls specifications.
- Options VPO and VPT are NOT available in conjunction with Options REI, REO, and WRE.

## VALVE CONTROLLERS AND OPTIONS

### Valve Controller Designations

**Hood exhaust (H or I)**—Includes an interface board and pressure switch for tri-state alarming and connection to fume hood monitor.

**Hood exhaust with relay (R or Q)**—Same as analog H or I, but also includes an alarm relay output.

**Associated analog valve (S or P)**—Depopulated versions of the analog valve controller.

**Valve Options** (components added to enhance a valve's functions)

**Single square flange (SFX)**—Provides a single connection from round single body valve to square duct. On inlet of single body exhaust valves; discharge of single body supply valves. Typically used in Neutralizer™ applications.

**Square flanges - both valve ends (SFB)**—Square flanges on both ends of a round single-body valve provide connections to square duct work.

**Scaling function module (SFM)**—Electronic board installed on an analog E or M valve controller to adjust input signal for offset control, inverse operation or scaling.

**Pressure switch (PSL)**—Detects low static pressure across the valve. Installed on non-hood exhaust valves to provide low static pressure alarm monitoring.

**Power supply (VPO, VPT)**—Valve-mounted power supply provides +15 Vdc, -15 Vdc power to Phoenix Controls system.

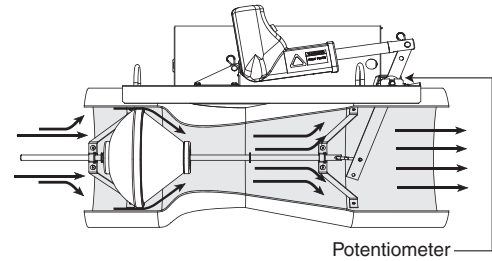

### POINTS AND WIRING (See submittal wiring diagram for project-specific details.)

#### Analog Pneumatic Controller

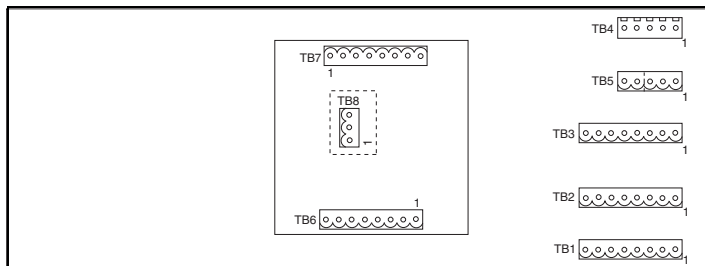

#### LEGEND:

Dashed box around TB8 denotes HR option.

#### Analog Electric Controller

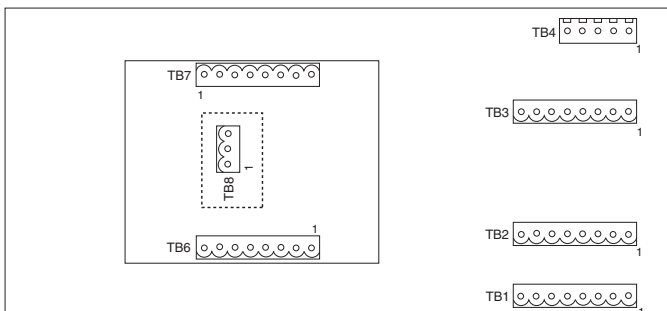

#### LEGEND:

Dashed box around TB8 denotes HR option.

#### NOTES:

1. Cable is 22 ga. Eight-conductor is Belden 9421 or equivalent.
2. Each termination block (except TB4) uses a depluggable connector with screw-down terminations for ease of installation.
3. Electric actuation power wiring must be 14 AWG, connected in a star configuration.

#### TERMINAL BLOCK—ANALOG PNEUMATIC VALVE CONTROLLERS

Terminal Block	Typical Function	No. of Terminations
TB1*	Input from command device	8
TB2*	Output	8
TB2S*	Booster valve output	8
TB3	Prior booster valve input	8
TB4	Pot and pressure switch	5
TB5	Power input	3**
TB6*	Input from monitor (H/I card)	8
TB7*	Hood valve output (H/I card)	8

#### TERMINAL BLOCK—ANALOG ELECTRIC VALVE CONTROLLERS

Terminal Block	Typical Function	No. of Terminations
TB1*	Input from command device	6
TB2*	Output	6
TB2S*	Booster valve output	6
TB3	Prior booster valve input	6
TB4	Pot and pressure switch	5
TB5	Power input and test	3**
TB6*	Input from monitor (H/I card)	8
TB7*	Hood valve output (H/I card)	8
TB8*	Relay output	3
J1	Power input (see note 3)	2

\*These terminal blocks are application specific and are provided only when required.

\*\*For electric actuation, S and P type valve controllers, TB5 is a 5 pin.

# Typical Wiring Diagrams

## ANALOG PNEUMATIC VALVES

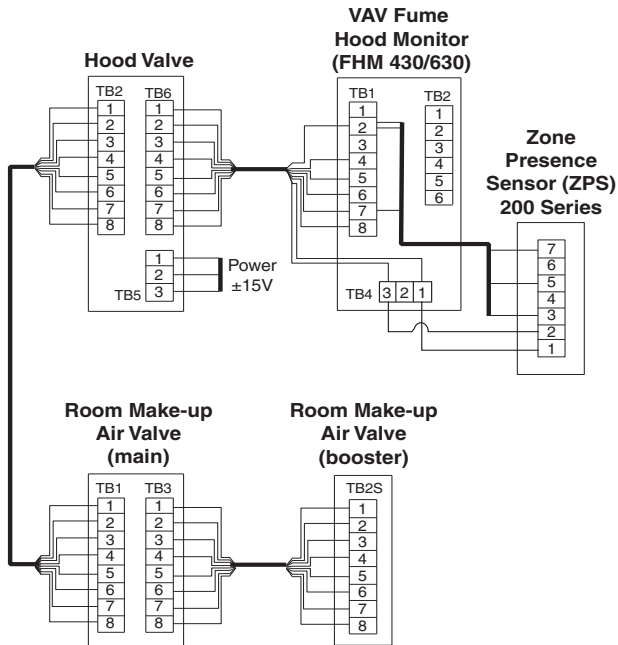

## ANALOG ELECTRIC VALVES

