

DIMENSIONS AND WEIGHTS

Single
(EXV-electric)

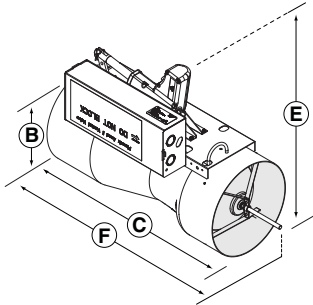

Dual
(MAV-pneumatic normally closed shown)

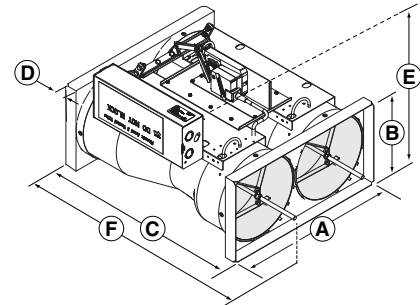

Triple
(MAV-pneumatic normally closed shown)

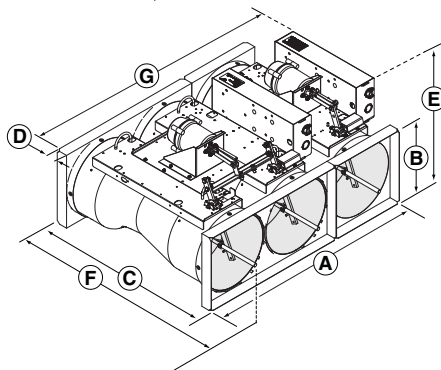

Quad
(CVV shown)

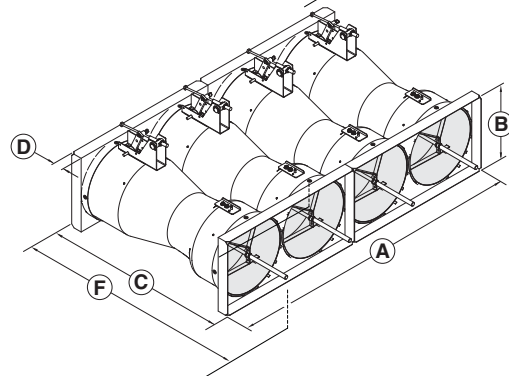

	A*		B*		C		D		E**		F		G		Weight (CVV valves)		Weight (all others)	
	in.	mm	in.	mm	in.	mm	in.	mm	in.	mm	in.	mm	in.	mm	lbs	kg	lbs	kg
Single 8	—	—	7.88	200	23.50	597	—	—	14.13	359	28.00 ¹	711	10.13	257	7	3.2	12	5.5
Single 10	—	—	9.67	246	21.75	552	—	—	16.13	410	26.20 ¹	665	11.20	284	7	3.2	13	6.0
Single 12	—	—	11.84	301	26.81	681	—	—	18.13	461	32.56 ¹	827	12.13	308	9	4.1	16	7.3
Single 14	—	—	13.88	353	30.00	762	—	—	21.43	544	36.59 ¹	968	13.52	343	13	6.0	20	9.1
Dual 10	20.13	511	10.13	257	24.75	629	1.5	38	16.77	426	27.70	704	21.52	547	18	8.2	30	13.6
Dual 12	24.13	613	12.13	308	29.81	757	1.5	38	18.75	476	34.60	879	24.76	629	23	10.4	36	16.3
Triple 12	37.06	941	12.13	308	29.81	757	1.5	38	18.75	476	34.60	879	36.77	934	32	14.5	52	23.6
Quad 12	48.26	1226	12.13	308	29.81	757	1.5	38	18.75	476	34.60	879	48.65	1236	46	20.9	72	32.7
Dual 14	30.00	762	15.00	381	33.00	838	1.5	38	21.43	544	38.09	968	28.90	734	37	16.8	50	22.7
Triple 14*	45.00	1143	15.00	381	33.00	838	1.5	38	21.43	544	38.09	874	42.27	1074	40	18.2	70	31.8
Quad 14*	60.00	1524	15.00	381	33.00	838	1.5	38	21.43	544	38.09	874	57.13	1452	74	33.6	100	45.4

1. For this valve's flanged measurement, add 1.5" for single or 3.0" for double flanged.

* indicates outer dimension

**indicates maximum for valve type (some configurations may be smaller)

NOTES:

- Leave 14" (356 mm) access space to all electronic controls.
- Single valve circular flange dimensions are in the *Flanges for Single Body Valves* Product Data Sheet.
- Dimensions given are accurate to ±0.13" (3 mm).
- Triple and quad valve units are shipped as single and dual valves. Field assembly is required.
- Slip type flange material is 20 ga. galvaneal with powder coating.
- Valves need no additional straight runs before or after valve. However, as identified by dimension F above, the shaft needs up to 9.0" (229 mm) of unobstructed space in the duct on the inlet side of the valve in the maximum flow position.
- Weights given are approximate and listed for reference only. For shipping, add 6 lbs. (2.7 kg) for singles and duals; 12 lbs. (5.4 kg) for triples and quads.
- Linkages for NO valves and some NC valves must be connected by installer (pneumatic valves).
- E clip supplied for CVV adjustment mechanism. Must be inserted by installer (see Figure 2 next page).
- Dimensions do not account for valves with 3/8" (9.5 mm) insulation.
- Refer to the installation instructions on the next page for additional details.
- The 14-inch valve is not available with a pneumatic actuator at this time.

INSTALLATION

1. Read all instructions completely prior to installing valves.
2. Check that tag number on valve label matches HVAC schedule.
3. Verify correct airflow direction and orientation of the valve in the ductwork (e.g., horizontal). NOTE: Valves mounted out of horizontal or vertical position (as determined by a level) will affect valve performance.
4. Allow a minimum of 14 in. (356 mm) of free unobstructed space around the valve for access. In general, the valve may be installed in a 360° rotation. However, single body horizontal hood valves should be installed so that the pivot arm (see Fig. 1 and 4) is located between 8 and 4 o'clock (not within 4 to 8 o'clock).
5. Allow 9.0" (229 mm) of unobstructed space in the duct on the valve's inlet side for the shaft to reach the maximum flow position.
6. Linkage Connection—Many valves require field connection of pivot arm (see Figs. 1 and 2).
7. For multiple valves, assemble the valve sets on the floor using duct sealant and fasteners (see Fig. 3). Slip L style mating piece onto valve flange.
8. Use duct sealant on all valve/duct connections (or flange gaskets for circular flanges).
9. Install a hanger stock to support the ductwork within 12 in. (305 mm) of the valve connection. Install valve by sleeving it into the duct after the hanger stock is in place.
10. Follow the appropriate installation diagram (see Fig. 5). NOTE: Screws, fasteners, duct sealant, hanger stocks, companion flanges, and gaskets are not provided by Phoenix Controls.

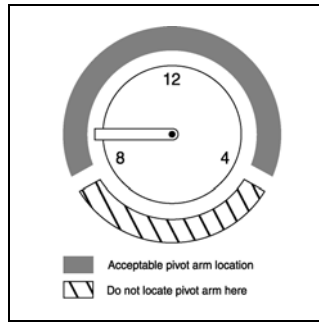

Fig. 4 Pivot arm orientation installed.

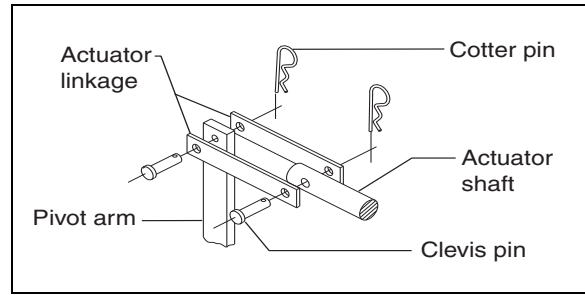

Fig. 1 Linkage connection for normally closed pneumatic valves (normally open valves similar).

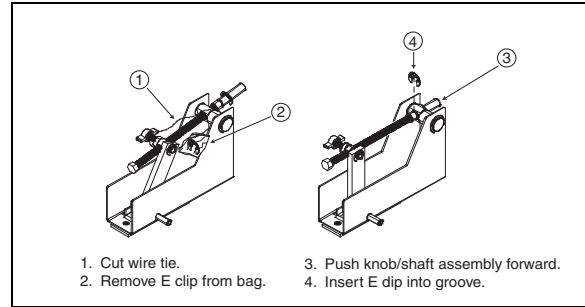

Fig. 2 Constant volume valves.

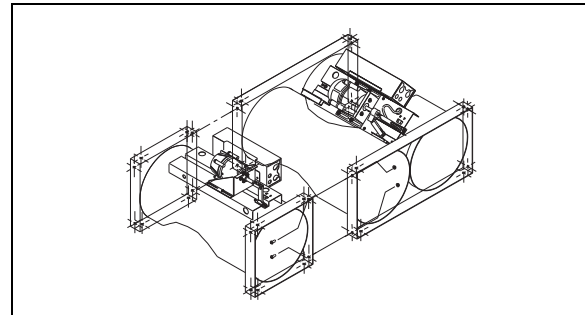

Fig. 3 Points for fastening multiple assemblies.

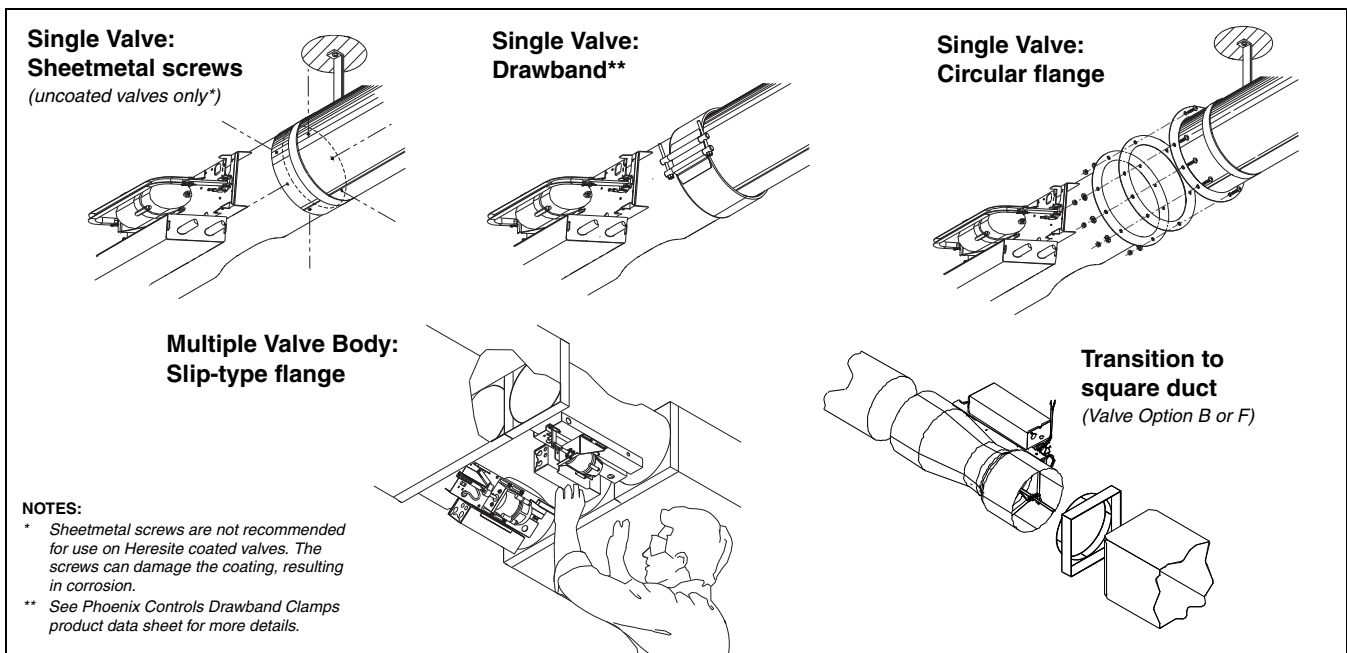
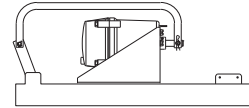
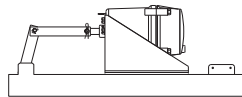
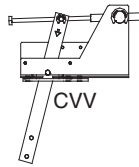

Fig. 5 Valve installation methods.

VALVE FAMILY CONTROL TYPES



PSV/BSV-pneumatic
normally closed

PEV/BEV-pneumatic
normally open



MAV-pneumatic
normally closed

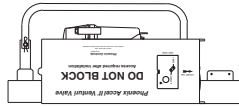

EXV-pneumatic
normally open



MAV-electric normally closed
or EXV-electric normally open

MAINTENANCE

Accel II valves require no ongoing preventive maintenance. Once the field engineer has completed the field startup, the valves will provide years of continuous operation.