



**APPLICATIONS**

**Airflow Volume Control**

Variable air volume (VAV) control schemes are commonly used for fume hoods, general exhaust, and room supply air.

- Fume hood control—For typical fume hood applications, high-speed (< 1 second speed of response) actuation is required. The Celeris Valve Controller (CVC) interfaces with our fume hood monitors for actuation. The Celeris platform provides room-level control functions in either standalone or integrated systems.
- Tracking pair control—In applications where make-up air control and an interface with our fume hood monitors are not required, low-speed electric actuation is an economical solution for room-level control in either standalone or integrated systems.

Celeris controllers provide room pressurization, temperature, humidity, occupancy and emergency control functions in make-up air and tracking pair control applications.

**SPECIFICATIONS**

**Construction**

- 16 ga. spun aluminum valve body with continuous welded seam
- Valve bodies available as uncoated aluminum or with corrosion-resistant baked phenolic coatings
- Composite Teflon® shaft bearings
- Spring grade stainless steel spring and polyester or PPS slider assembly
- Supply valves\* insulated with 3/8" (9.5 mm) flexible closed-cell polyethylene. Flame/smoke rating 25/50. Density is 2 lb/ft³ (32 kg/m³)

**Operating Range**

- 32-122 °F (0-50 °C) ambient
- 10-90% non-condensing RH

**Performance**

- Pressure independent over 0.6"-3.0" WC (150-750 Pa) drop across valve
- Volume control accurate to ±5% of airflow command signal
- No additional straight duct runs needed before or after valve
- Available in flows from 35-10,000 CFM (60-16,990 m³/hr)
- Response time to change in command signal:
  - <1 second (control type M and N)
  - <1 minute (control type L)
- Response time to change in duct static pressure: <1 second

**Pneumatic Actuation**

(Not available with the 14-inch valve)

- 20 psi (-0/+2 psi) with a 20 micron filter main air required
- Compressor sizing: Accel II Valves are not continuous air-consuming devices. For compressor sizing, use:
  - single and dual valves: 10 scfm
  - triple and quad valves: 20 scfm

**Sound**

Designed for low sound power levels to meet or exceed ASHRAE noise guidelines.

**CVC Controller**

Power: 24 Vac (±15%) @ 50/60 Hz

Power Consumption:

Control Type	Single	Dual
L (low-speed electric)	13 VA	17 VA
M (high-speed electric)	70 VA	70 VA
N (pneumatic)	11 VA	11 VA

I/O available for connecting field devices:

- 3 universal inputs. Accepts volt, mA, ohms or NTC 2 or 3 thermistor signals.
- 1 digital input
- 2 analog outputs. Provides volt or mA signals.
- 1 digital output (Type C, 1 amp @ 24 Vac/Vdc)
- Input accuracy: Voltage, current, resistance: ±1% full scale
- Output accuracy
  - 0 to 10 Vdc: ±1% full scale into 10 kΩ minimum
  - 4 to 20 mA: ±1% full scale into 500 Ω +0/-50 Ω

Agency compliance:

- CSA
- CE
- FCC Part 15, Subpart J, Class A

Room-level communications: FTT-10, 78 KB, bus topology, LonTalk™ network  
 Building-level communications: TP-1250, 1.2 MB, bus topology, LonTalk™ network



See wiring diagrams

\* Not applicable to CVV series.

Teflon is a registered trademark of DuPont Company.  
 LonWorks is a registered trademark of Echelon Corporation.

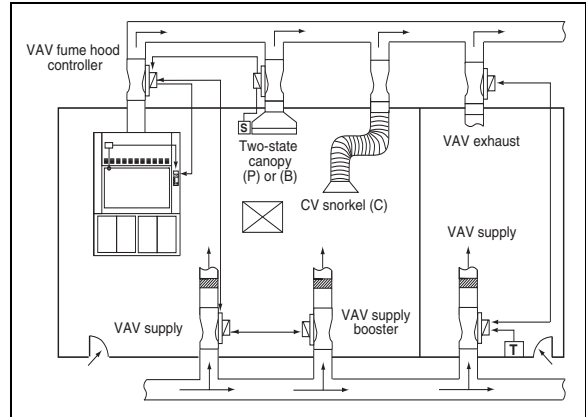

**FEATURES**

FEATURE/OPTION	VAV (EXV/MAV)		
	L	N	M
Control type	L	N	M
Actuator type	Low-speed electric	Pneumatic *	High-speed electric
Flow feedback signal	✓	✓	✓
Failsafe	Last Position	NO/NC	NO/NC/Last Position
Factory-insulated valve body (supply)	✓	✓	✓
Field-adjustable flow	✓	✓	✓
Flow alarm via feedback circuit	✓	✓	✓
Flow alarm via pressure switch	Option	Option	✓
Low noise diffuser construction†	✓	✓	✓

All valves include a pressure-independent assembly and factory-calibrated position controller.

† Accel II valves are designed to reduce sound over all frequencies, but significantly target the lower bands (125-500 Hz) to help eliminate the need for silencers.

\* The pneumatic actuator is not available for the 14-inch valve at this time.

**FCC COMPLIANCE FOR DIGITAL VALVES**

**WARNING:** Changes or modifications to this unit not expressly approved by the party responsible for compliance (Phoenix Controls) could void the user's authority to operate the equipment.

**NOTE:**

- This equipment has been tested and found to comply with the limits for a Class A digital device, pursuant to Part 15 of the FCC Rules. These limits are designed to provide reasonable protection against harmful interference when the equipment is operated in a commercial environment.
- This equipment generates, uses, and can radiate radio frequency energy and, if not installed and used in accordance with the instruction manual (Phoenix Controls product data sheets and wiring diagrams), may cause harmful interference to radio communications.
- Operation of this equipment in a residential area is likely to cause harmful interference in which case the user will be required to correct the interference at his own expense.

## ORDERING GUIDE

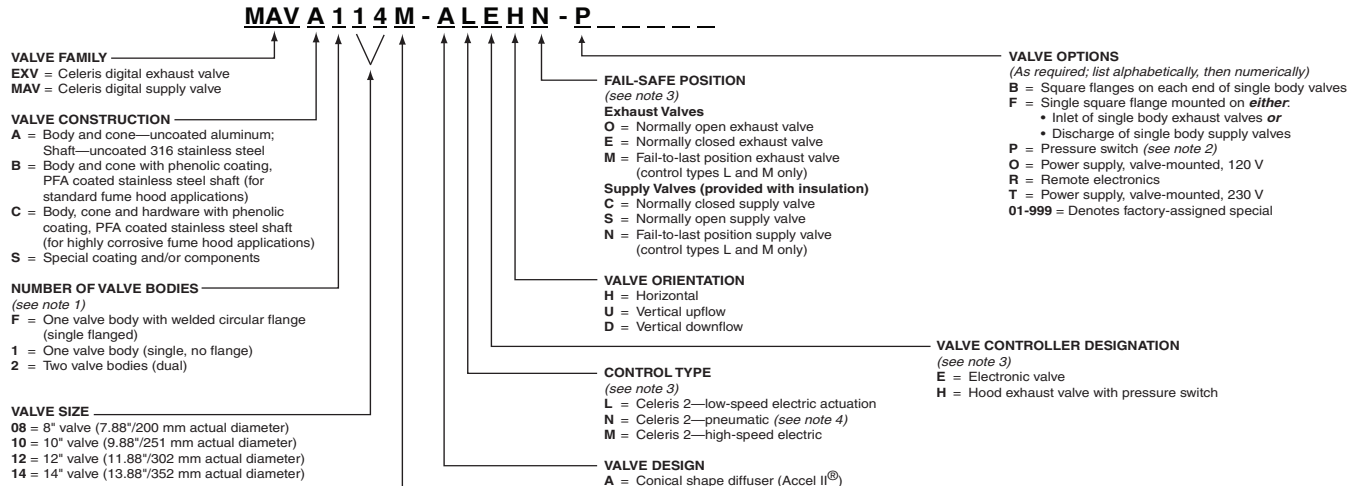

**FLOW/PRESSURE OPERATING RANGE**

Designation	Size	Operating Range in CFM (m3/hr)				Pressure Drop Across Valve 0.6-3.0" WC (150-750 Pa)
		Single	Dual	Triple	Quad	
M = Medium pressure	08"	35-700 (60-1175)	—	—	—	
	10"	50-1000 (85-1700)	100-2000 (170-3350)	—	—	
	12"	90-1500 (150-2500)	180-3000 (300-5000)	See note 1	See note 1	
	14"	200-2500 (339-4247)	400-5000 (680-8495)	See note 1	See note 1	

- NOTES:**
- For triples, specify one single with B option and one dual valve; for quads, specify two dual valves. Triples and quads will represent two nodes on the network.
  - Pressure switch set point = 0.3" WC (75 Pa).
  - Fail-safe options: Normally closed (NC) and normally open (NO) for high-speed electric and pneumatic only. Fail-to-last position for high- and low-speed electric only.
  - Not available in the 14-inch valve size.

## VALVE CONTROLLERS AND OPTIONS: CELERIS VALVES

### Valve Controller Designation

**Controller Type E**—Suitable for supply, make-up air and general exhaust valve applications.

**Controller Type H**—Suitable for fume hood applications and includes a pressure switch for alarming.

### Valve Options *(components added to enhance a valve's functions)*

**Single square flange (F)**—Provides a single connection from a round single body valve to a square duct (on the inlet of single body exhaust valves; discharge of single body supply valves). Typically used in Neutralizer™ applications.

**Two square flanges (B)**—Transitions each end of a single body valve from a round to square duct.

**Pressure switch (P)**—Detects low static pressure across the valve. Installed on non-hood exhaust valves to provide low static pressure alarm monitoring.

**Power supply (O, T)**—Valve mounted power supply provides +15 Vdc, -15 Vdc power to Phoenix Controls fume hood monitors and zone pressure sensors.

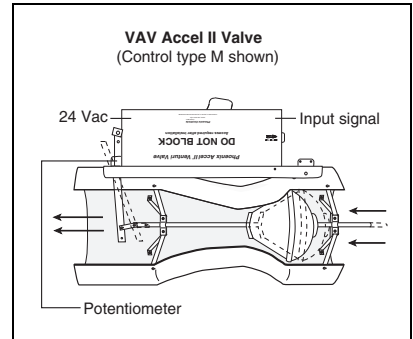

**POINTS AND WIRING** (See submittal wiring diagram for project-specific details.)

**Celeris Valve Controller**

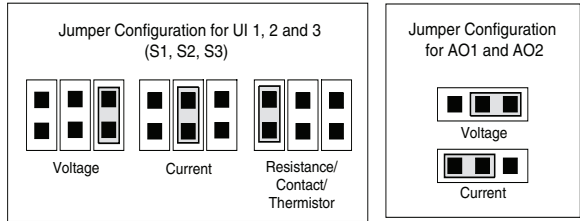
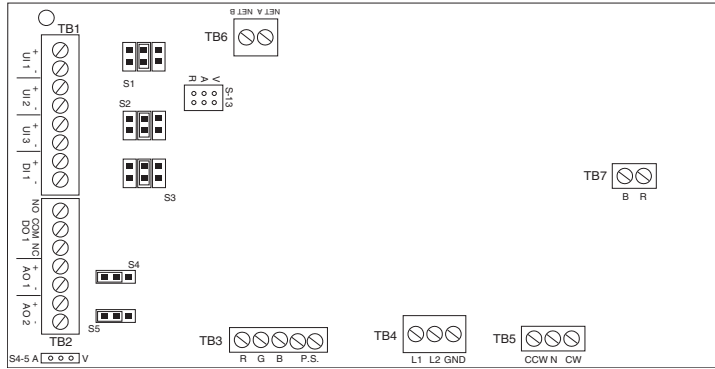

**TERMINAL BLOCKS—CELERIS VALVE CONTROLLERS**

Terminal Block	Typical Function	Number of Terminations
<b>TB1</b>	Input connections	8
<b>TB2</b>	Output connections	7
<b>TB3</b>	vPot and pressure switch	5
<b>TB4</b>	Power (24 Vac input)	2
<b>TB5</b>	Actuator (control type L only)	2
<b>TB6</b>	Communication (FTT-10)	2
<b>TB7</b>	Actuator (control type M only)	2

**NOTES:**

- Power—14 AWG (Controller Type M). High-speed electric valves must be connected in a star configuration.
- Power—18 AWG (Controller Type L).
- Control signal—22 AWG multi conductor, twisted pair
- Communication—22 AWG level 4; 16 AWG Belden 8471 (or equivalent)
- Each termination block (except TB3, 5 and 7) uses a depluggable connector with screw-down terminations for ease of installation.

**Typical Wiring Diagrams**

**Hood Applications**

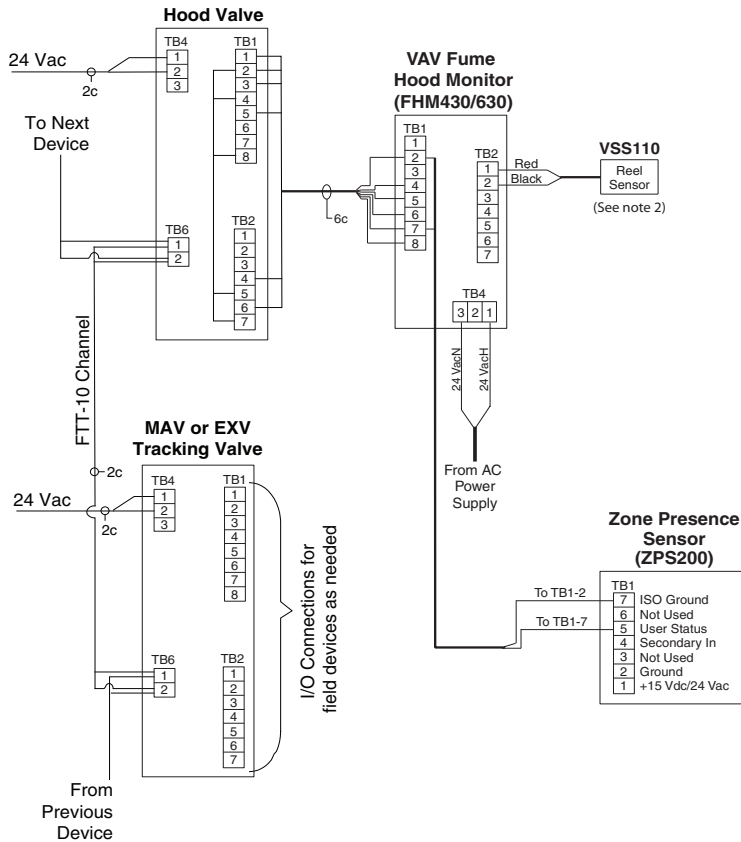

**Tracking Pair Applications**

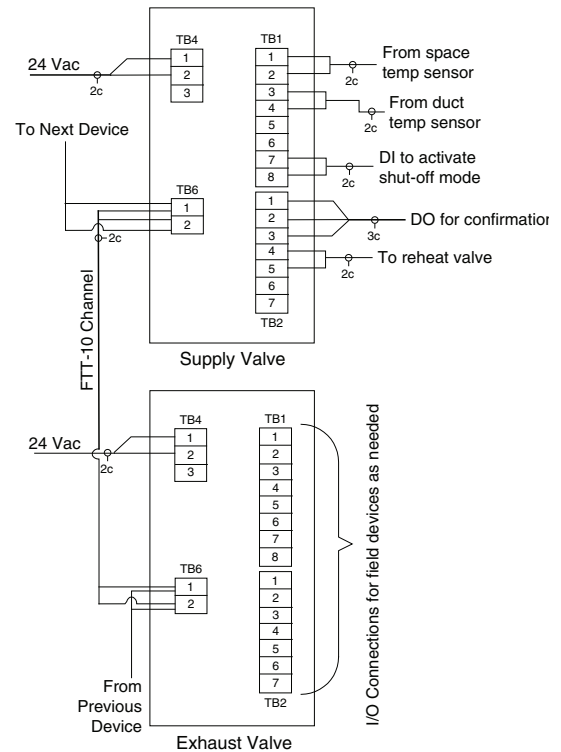

**Notes:**

- Eight-conductor wire is Belden 9421 (22 AWG) or equivalent. (Tape back unused conductors.)
- Sash sensor is provided with two-conductor cable. See combination sash sensors for exception.

## WIRING

### Transformers

The Celeris Valve Controller (CVC) requires the use of a step-down transformer (either 120/24 volt or 240/24 volt). Any transformer used to power CVCs must meet the requirements of an NEC Class 2 circuit.

- The secondary transformer must be limited to a maximum of 30 Vac.
- Secondary power shall be current limited with either internal circuit breaker protection or with a four-amps slow-blow fuse, in accordance with NEC Class 2 power requirements.

Phoenix Controls offers the following recommendations; however, designers, installers and owners should always consult their national and local electrical codes before selecting transformers for their systems.

- Transformers should not exceed 100 VA. Use multiple transformers, rather than larger transformers, when more than 100 VA is required.
- Each pressurization zone should have either a dedicated single-phase primary circuit or a secondary circuit disconnect.
- If an earth ground is provided, it should not be connected to the CVC, even though there is a three-terminal connector on the CVC board.

*NOTE: AC line voltage polarity must be maintained on all CVC and AC powered ancillary devices.*

### Transformer Sizing

To size a transformer, all of the VA loads for the circuit must be totaled. This table outlines the power ratings of Celeris products and related outside purchased equipment. Use these values to size the power transformers for the Celeris system.

Celeris Valve Controller (CVC)		
Control type L (low-speed electric)	Single valve body	13 VA
	Dual valve body	17 VA
Control type M (high-speed electric)	Single valve body	70 VA
	Dual valve body	70 VA
Control type N (pneumatic)	Single and dual valve bodies	11 VA
External Devices		
Router/repeater modules		2 VA
Sensor	Approved thermistor	0 VA
Heating valve	Belimo LM24 (2-state)	3 VA
Heating valve	Belimo LM24SR (propor)	4 VA
Each 4-20 mA device	Example: transducers	0.5 VA

### Power Conductor Sizing

For low-speed valves in a bus configuration:

As a rule of thumb for loads up to 100 VA, use 18 AWG cable with a maximum length of 110 feet (33 meters) between the transformer and the last daisy-chained device.

For a more exact length per load number, refer to this chart.

For high-speed valves in a star configuration, refer to the 14 AWG column of this chart.

Maximum wire length (in feet) given a wire gauge and VA delivery by transformer					
VA Delivered	Wire Gauge				
	14 AWG	16 AWG	18 AWG	20 AWG	22 AWG
10	2880	1743	1095	695	433
20	1440	871	548	347	216
30	960	580	365	213	144
40	720	435	274	174	108
50	576	348	219	139	86
60	480	290	182	115	72
70	411	249	156	99	61
80	360	217	136	86	54
90	320	193	121	77	48
100	288	174	110	69	43

*NOTE: Control Type M (high-speed electric actuation) must use at least 14 AWG. Wired in a star or home run configuration (not daisy-chained).*

## WIRING (CONTINUED)

---

### Network Wiring

#### Room-level Network

Echelon Corporation has tested and approved 5 cables types for use with the FTT10 communications transceiver. Based on availability, cost and maximum distance limitations, we have focused our recommendation to two cable types:

- Generic NEMA level 4 cable, 22 AWG (0.65 mm)\*
- Belden 8471, 16 AWG (1.3 mm) cable (or equivalent)

*NOTE: \*Level 4 cable specified by Echelon as originally defined by the NEMA differs from the Category 4 specification proposed by the Electronic Industries Association/Telecommunication Industry Association (EIA/TIA).*

The cables Phoenix Controls recommends are stranded, two-conductor, twisted-pair (TP) without a shield. A shield, or drain wire, is not required for Celeris communications wiring and should not be used. Both of these cables are available from multiple sources either solid or stranded, in plenum and non-plenum rated versions.

- If two conductors are to be placed in a terminal opening, twist the bare conductors prior to inserting these in the terminal opening.
- If a wall-mounted sensor with a communications jack is used, the connections to the jack must be treated as either a bus connection or an EOL connection.
- While the room-level communications wiring is not polarity sensitive, it is recommended that a consistent color-coding and polarity convention be followed.
- Each terminal on the terminal block will accommodate up to two 16 AWG (1.3 mm) stranded conductors.
- Communications connections are to be made following a bus or daisy chain topology.
- Two end-of-line (EOL) terminators must be installed, one at each end of the room-level network.

#### Maximum Cable Lengths

- When using Level 4 cable operating in a bus topology, the maximum cable length is 4500 feet (1370 meters).
- When using 16 AWG cable operating in a bus topology, the maximum cable length is 8800 feet (2680 meters).

#### Phoenix Controls Wiring Recommendations

- Use cables recommended by Phoenix Controls.
- Stranded wire is strongly recommended for ease of installation.
- Follow good wiring practices:
  - Do not run the communications cable in the same conduit or wire way as the power cables.
  - If the communications cables must cross power cables, it is best to do so at a 90-degree angle.
  - Shield or drain wires, if present, should be wrapped with insulating tape to prevent contact with exposed conductors or contacts.
  - Maintain a consistent color code or polarity all the way through the wiring system.
  - All connections must meet the requirements of an NEC Class 2 circuit.
  - Local and national electrical codes take precedence.