

APPLICATIONS

Airflow Volume Control

Constant volume (CV)—Constant volume controllers (C) are typically used for snorkels, biosafety cabinets, CV fume hoods, ventilated cabinets and outside air regulation.

Two-position—Pneumatic controllers (P) are typically used for canopy hoods and two-position fume hoods. Base upgradable controllers (B) can be substituted when flow feedback is required or upgradability to VAV is desired.

SPECIFICATIONS

Construction

- 16 ga. spun aluminum valve body with continuous welded seam
- Valve bodies available as uncoated aluminum; or with corrosion-resistant baked-on phenolic coating, or with PVDF (Polyvinylidene fluoride) coating
- Composite Teflon® shaft bearings
- Spring grade stainless steel spring and polyester or PPS slider assembly
- Supply valves insulated with 3/8" (9.5 mm) flexible closed-cell polyethylene. Flame/smoke rating 25/50. Density is 2.0 lb/ft³ (32.0 kg/m³)

Operating Range

- 32-122 °F (0-50 °C) ambient
- 10-90% non-condensing RH

Sound

Designed for low sound power levels to meet or exceed ASHRAE noise guidelines.

Performance

- Pressure independent over a 0.6"-3.0" WC (150-750 Pa) drop across valve
- Volume control accurate to ± 5% of airflow feedback signal
- No additional straight duct runs needed before or after valve
- Available in flows from 35-10,000 CFM (60-16,990 m³/hr)
- Response time to change in duct static pressure: <1 second

Pneumatic Actuation

- Only applicable to PEV, PSV and BEV/BSV
- 20 psi (-0/+2 psi) with a 20 micron filter main air required
- Compressor sizing: Accel II Valves are not continuous air-consuming devices. For compressor sizing, use:
 - single and dual valves: 10 scim
 - triple and quad valves: 20 scim

Flow Feedback Card

Mounting

The flow feedback card is factory installed in a PPC flame retardant black box enclosure.

Enclosure

Dimensions: 6 x 3.2 x 1.9 inches
Color: Black

Power

±15 Vdc, ± 15%, 35 mA
Or
24 Vac, ± 15%, 50/60 Hz, 1.5 VA

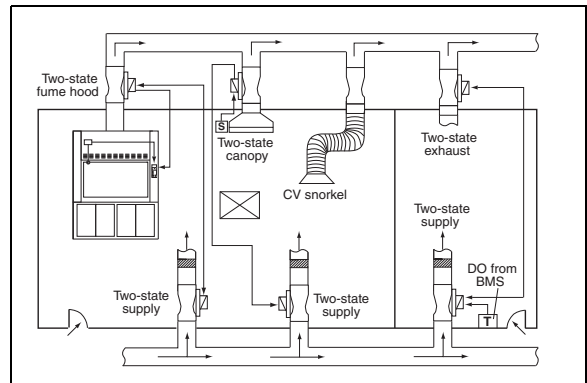

FEATURES

FEATURE/OPTION	CONSTANT VOLUME (CV)	TWO-POSITION (PEV/PSV)	UPGRADABLE (BEV/BSV)
Control type	C Constant Volume	P Pneumatic	B Base Upgradable
Actuator type	—	Pneumatic	Pneumatic or CV
Flow feedback signal	—	—	Option*
Failsafe	Fixed	NO/NC	NO/NC**
Factory-insulated valve body (supply)	Option	✓	✓
Field-adjustable flow	✓	✓	✓
Flow alarm via feedback circuit	—	—	—
Flow alarm via pressure switch	Option	Option	Option
Low noise diffuser construction†	✓	✓	✓

All valves include pressure-independent controller.

†Accel II valves are designed to reduce sound over all frequencies, but significantly target the lower bands (125-500 Hz) to help eliminate the need for silencers.

* Not available with the 14-inch valve at this time.

** Fixed fail-safe for CV actuation.

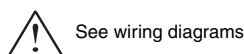

Teflon is a registered trademark of DuPont Company.

ORDERING GUIDE

BSV A 1 10 M - A B F H C - PSL

VALVE FAMILY

Note: Supply valves come standard with insulation.

- CSV = Constant volume supply valve
- CEV = Constant volume exhaust valve
- PSV = Pneumatic supply valve (no feedback)
- PEV = Pneumatic exhaust valve (no feedback)
- BSV = Base upgradable supply valve
- BEV = Basic upgradable exhaust valve

VALVE CONSTRUCTION

- A = Body and cone uncoated aluminum; uncoated 316 stainless steel shaft
- B = Body and cone with baked phenolic coating, PFA-coated 316 stainless steel shaft
- C = Body and cone with baked-on phenolic coating, hardware with titanium or baked-on phenolic coating, PFA-coated 316 stainless steel shaft
- D = Body and cone with a PVDF-coating, hardware with baked on corrosion-resistant epoxy phenolic coating or PVDF-coating, and a PFA-coated 316 stainless steel shaft; only available for 8-, 10-, and 12-inch Design A single-body valves no flanges

NUMBER OF VALVE BODIES

see Note 1

- F = Single valve with a welded circular flange
- 1 = One valve body, no flange
- 2 = Two valve bodies (dual); for PxV and BxV - only 10" and 12" valves
- 3 = Three valve bodies (triple) - analog and uncontrolled valves only; for PxV and BxV - only 12" valves
- 4 = Four valve bodies (quad) - analog and uncontrolled valves only; for PxV and BxV - only 12" valves

VALVE SIZE

- 08 = 8" valve (7.88"/200mm actual diameter)
- 10 = 10" valve (9.67"/246mm actual diameter)
- 12 = 12" valve (11.84"/301mm actual diameter)
- 14 = 14" valve (13.88"/352mm actual diameter); see Notes 1, 6

FLOW/PRESSURE OPERATING RANGE

M = Medium pressure operation; pressure independent over a range of 0.6 to 3.0" WC (150 to 750 Pa), associated pressure switch trips at 0.3" WC
See Standard Valve Flow/Pressure Operating Range table below

VALVE DESIGN

- A = Conical shape diffuser (Accel II); this valve is not available as a shut-off valve

VALVE OPTIONS

- EVI = Exhaust valve with insulation blocks and insulation
- IBO = Valve with insulation blocks only (no insulation provided)
- PSL = Pressure switch, low limit (0.3" WC); one per each valve body
- REI = Remote electronics, indoor (BxV only) - see Notes 2, 3
- REO = Remote electronics, outdoor, pneumatic actuator only (BxV only) - see Notes 4, 5
- SFB = Square flanges on both ends of single body valves
- SFX = Single square flange mounted on either the exhaust inlet or supply discharge
- SHA = High wattage 24 Vac solenoid valve, controlled by non-Phoenix device (for BxV - Control Type B only)
- SHD = High wattage 24 Vdc solenoid valve, controlled by FHM530 monitor (for BxV - Control Type B only)
- VPO = Power supply valve-mounted, 120 Vac to +/- 15 Vdc (BxV Control Types B and F only; not available in conjunction with REO, REI)
- VPT = Power supply valve-mounted, 230 Vac to +/- 15 Vdc (BxV Control Types B and F only; not available in conjunction with REO, REI)

FAIL SAFE POSITION

- C = Normally closed valve; Control Types P and B only
- O = Normally open valve; Control Types P and B only
- Z = Fails to last position (not available for PxV)

VALVE ORIENTATION

- H = Horizontal
- U = Vertical upflow
- D = Vertical downflow

VALVE CONTROLLER DESIGNATION

- N = No electronics
- T = Two-state controller and high wattage 24 Vdc solenoid valve - no feedback; Control Type B only
- F = Flow feedback in a small black plastic enclosure
- G = Two-state controller, flow feedback and high wattage 24 Vdc solenoid valve; Control Type B only
- S = Flow feedback in a standard metal enclosure (BxV only)

CONTROL TYPE

- C = Constant volume (field adjustable with hex head driver)
- P = Pneumatic (PxV only)
- B = Base upgradable - pneumatic (BxV only)
- F = Fixed, field adjustable with knob and increase/decrease flow label (BxV only)
- I = Floating point IP54 electric actuator with fail-to-last position (BxV only)
- Z = Proportional electric actuator with fail-to-last position (BxV only)

STANDARD ANALOG VALVE FLOW/PRESSURE OPERATING RANGE

Designation	Size	Operating Range in CFM (m3/hr)				Pressure Drop Across Valve
		Single	Dual	Triple	Quad	
M = Medium Pressure	08"	35-700 (60-1185)	—	—	—	0.6-3.0" WC (150-750 Pa)
	10"	50-1000 (85-1695)	100-2000 (170-3390)	—	—	
	12"	90-1500 (155-2545)	180-3000 (310-5090)	270-4500 (465-7635)	360-6000 (620-10180)	
	14"	200-2500 (340-4245)	400-5000 (680-8490)	600-7500 (1020-12735)	800-10000 (1360-16980)	

NOTES:

1. BxV 14-inch Pneumatically actuated and Fixed, Field-Adjustable valves are only available in single-body units without flow feedback.
2. Option REI: Remote Electronics, Indoor installations only.
 - * For low-speed electric actuators (Control Type = I or Z): the distance to the valve controller is limited to 150 feet (45.7 meters) of 22 gauge cable.
 - * For pneumatic actuators (Control Type = B): the distance to the valve controller is limited to 75 feet (22.8 meters) of pneumatic tubing.
3. Option REI with BXV valves must have flow feedback (Controller Designation = F, G, or S).
4. Option REO: Remote Electronics, Outdoor installations only. Limited to Pneumatically actuated valves only (Control Type = B). Horizontal orientation only. Includes sealed Vpot, small weather-resistant TP34 box mounted on base channel for others to connect Vpot cables, and a valve controller in an enclosure that has been disconnected from the base channel and shipped in the same box as the valve.
 - * Maximum distance between remote mounted enclosure and valve is 75 feet (22.8 meters) (maximum allowable length of pneumatic tubing).
 - * Requires use of a dog house enclosure, provided by others, to protect valve from the elements and maintain temperature and humidity conditions within Phoenix specifications.
5. Option REO with BXV valves is only available with Pneumatic actuation (Control Type = B) and must have flow feedback (Controller Designation = F or S).
6. 14' Dual, Triple, and Quad available for CxV only.

VALVE CONTROLLERS AND DESIGNATIONS

Valve Controller Designation

Flow feedback (F)—Includes a feedback circuit board in a small black plastic enclosure installed on a Base series control valve to provide a 0-10 Vdc feedback signal scaled to indicate airflow. *NOTE: This option is not available for the 14-inch valve at this time.*

Flow Feedback Controller (S)—Includes a feedback circuit board in a standard metal valve enclosure installed on a Base-series control valve to provide a 0-10 Vdc feedback signal scaled to indicate airflow. *NOTE: This option is not available for the 14-inch valve at this time.*

Valve Options (components added to enhance a valve's functions)

Single square flange (SFX)—Provides a single connection from a round single body valve to a square duct. On the inlet of single body exhaust valves; discharge of single body supply valves. Typically used in Neutralizer™ applications.

Square flanges - both valve ends (SFB)—Square flanges on both ends of a round single-body valve provide connections to square duct work.

Solenoid valves (SHA, SHD)—Installed on a two-position valve to pneumatically switch the valve between maximum and minimum flows.

Pressure switch (PSL)—Detects low static pressure across the valve. Installed on non-hood exhaust valves to provide low static pressure alarm monitoring.

Power supply (VPO, VPT)—Valve-mounted power supply provides +15 Vdc, -15 Vdc power to Phoenix Controls base upgradable valves with flow feedback.

Constant Volume Valve

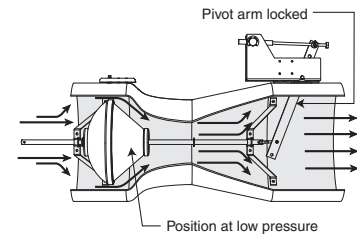

Two-Position Valve

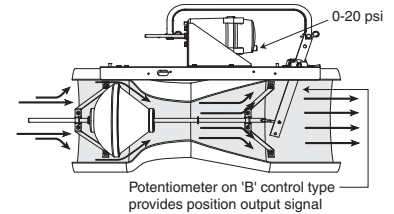

WIRING

Flow Feedback Option

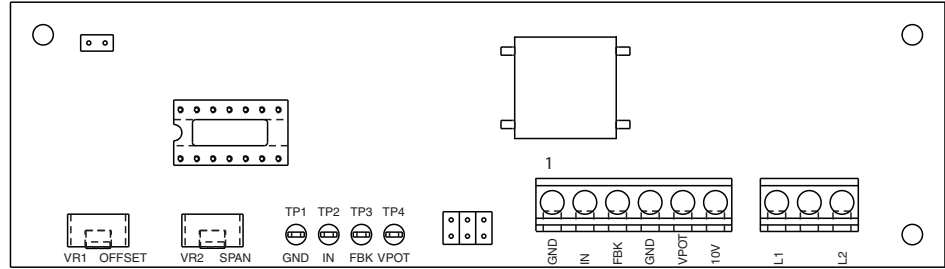

Typical Wiring Diagrams

(see Note 1.)

Hood Applications: Constant Volume

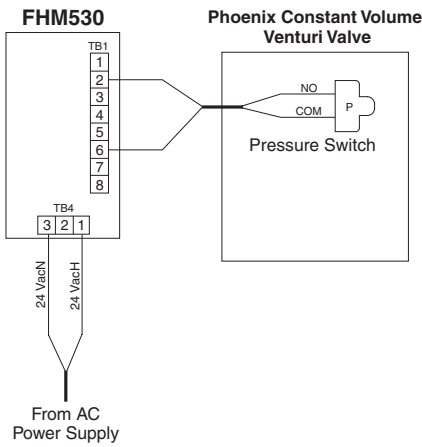

Hood Applications: Two-State with AC Solenoid

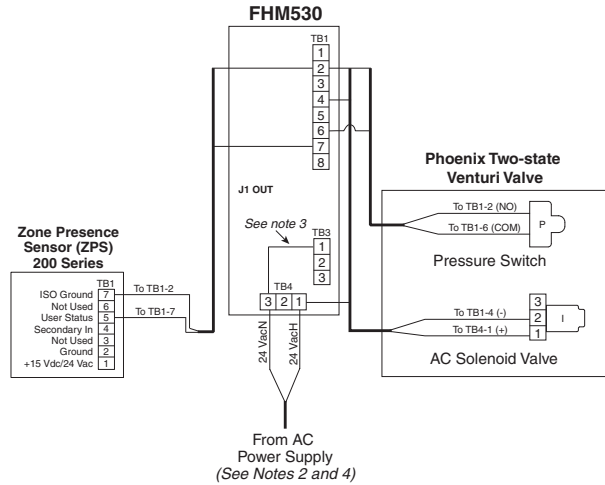

Flow Feedback Wiring (24 Vac and +/- 15 Vdc)

Flow Feedback Wiring

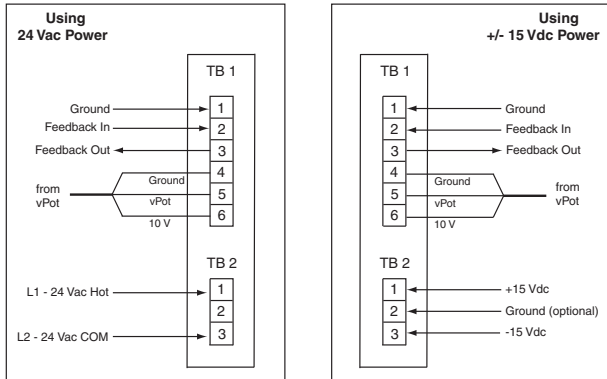

Hood Applications: Two-State with DC Solenoid

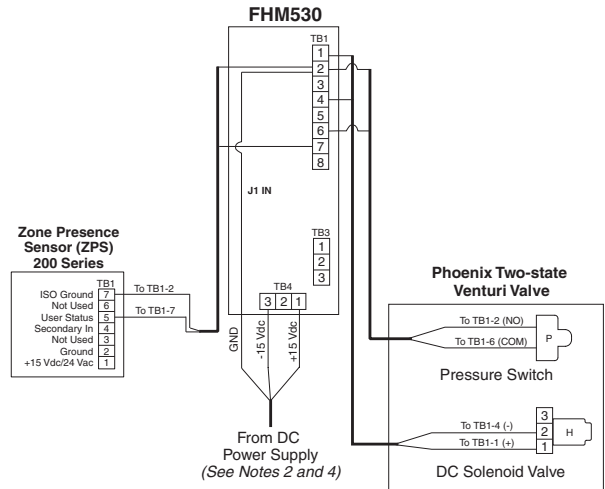

Notes:



1. See *Phoenix Recommend Cables* for more wiring information.
2. Fume hood monitor enclosure must be earth grounded via the mounting hole ground straps.
3. For AC-powered solenoid, two-position applications, you must install a field jumper between TB3-1 and TB4-3 (not required for DC-powered solenoids).
4. AC solenoids require the fume hood monitor to have AC power. DC solenoids require the fume hood monitor to have DC power.