

The Phoenix Controls MacroServer™ facilitates communication between the Celeris®, Theris® and Traccel® LONWORKS® systems and BACnet capable Building Management Systems (BMSs). The server performs bidirectional translations between LonTalk and BACnet to manage read requests and write commands between the BMS and the room-level devices, ensuring safe and reliable communications. The server also hosts the LNS database, along with a Configuration plug-in and several diagnostic utilities. The server functions as a data concentrator, collecting thousands of points from room-level devices and making these available to the BMS through a single Ethernet/IP connection.

The MacroServer is recommended for medium- to large-scale projects.

FEATURES

- Integration flexibility with most BMS vendors offering BACnet
- Supports up to 2000 devices or 6000 points
- External USB 56 K modem for remote configuration and/or troubleshooting
- Self-ventilated enclosure
- Built on a server-class computer platform
- Available in tower or rack-mount chassis

SPECIFICATIONS

Enclosure

Tower server enclosure
1U rack-mount chassis

Dimensions

Tower chassis:
17.5" H x 6.6" W x 18" D (444.5 mm H x 167.6 mm W x 457.2 mm D)

Rack-mount:
Form factor: 1U rack
1.68" H x 17.60" W x 21.50" D
(47.2 mm H x 447 mm W x 546.1 mm D)

Approx. Weight
38 lbs (17.3 kg)

Operating Temperature Range
50-95 °F (10-35 °C) ambient

Operating Humidity Range
8-85%, non-condensing

Power Requirements
Tower: 305 W, 115/230 V switchable power supply
Rack-mount: 345 W, Auto-sensing 115/230V

Modem
External USB supports communications to 56 K

Microprocessor

Pentium D, 2.8 GHz (minimum)

Memory

1 GB RAM (minimum)

Data Ports

Tower: 7 USB ports: 2 in front and 5 in the back
Rack-mount: 4 USB ports: 2 in front and 2 in the back

Disk Drive

1 internal CD-ROM drive 48x speed

Hard Drive

2 internal SATA drives, 80 GB each (minimum)

Network Interface

10 Base T/100 Base Tx/1000 Base Tx Ethernet adapter

Operating System

Windows XP Professional

BACnet is an exclusive trademark of ASHRAE.
Windows XP is a trademark of Microsoft Corporation.
LonWorks is a trademark of Echelon Corporation.



MacroServer Tower and Rack-mount

ORDERING GUIDE

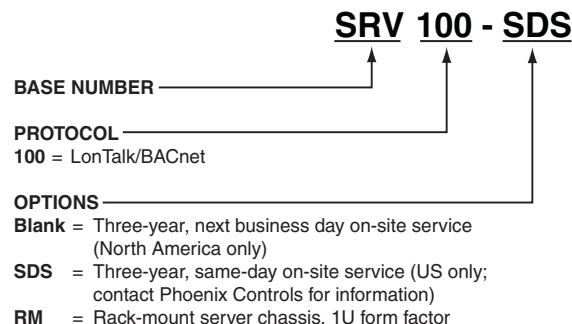

TABLE OF CONTENTS

Applications	2
Installation	3
Wiring	4
Points	5
Maintenance.....	8
Troubleshooting	8
BACnet Functionality of the MacroServer.....	8

Communication Protocols

BMS Network Protocol	
BMS protocol	BACnet over Ethernet BACnet over IP
BMS network connection	RJ-45
Implementation	Conformance Class 3 BIBBS—ASC (Application Specific Controller)
Data transfer rates (points per second)	Read requests/second: <ul style="list-style-type: none"> • 100 sustained • 300 peak Write commands/second: 30 maximum
Room-level Network Protocol	
Building network	ANSI 709.1—LonTalk protocol TP1250 transceiver
LonWorks network connection	22 AWG, Level IV, twisted-pair cable (no shield)

APPLICATIONS

The MacroServer provides seamless integration of the Celeris, Theris and Tracel systems and the Building Management System (BMS). It connects to the building-level (*communications*) network and the building Ethernet or IP (*integration*) network. The MacroServer functions as a server to the BACnet network and creates a virtual network of BACnet devices.

The MacroServer maintains two databases:

- One for all of the data available from the Celeris, Theris and Tracel network, which is constantly updated by each device on the network through a combination of Change of Value (COV) and heartbeat schemes
- A second for the BACnet objects (*points*) and associated properties, all of which may be *read* or *written to* by BMS BACnet client device(s)

Based on the level of functionality of the BMS, the MacroServer will use one or more BACnet Data Sharing Services to exchange data [see BACnet Interoperability Building Blocks (BIBBs) in the table, *BACnet Functionality of the MacroServer*, on page 8]. The MacroServer exceeds the functionality requirements of a BACnet Application Specific Controller (B-ASC). Any BACnet client on the Ethernet or IP network may request data, command set points or subscribe for change of value or event notification services from the Celeris, Theris or Tracel network.

The MacroServer includes tools to *filter* the data that is made available to the BMS, assign BACnet addresses, edit device and object properties, and validate proper integration using a standard Web browser.

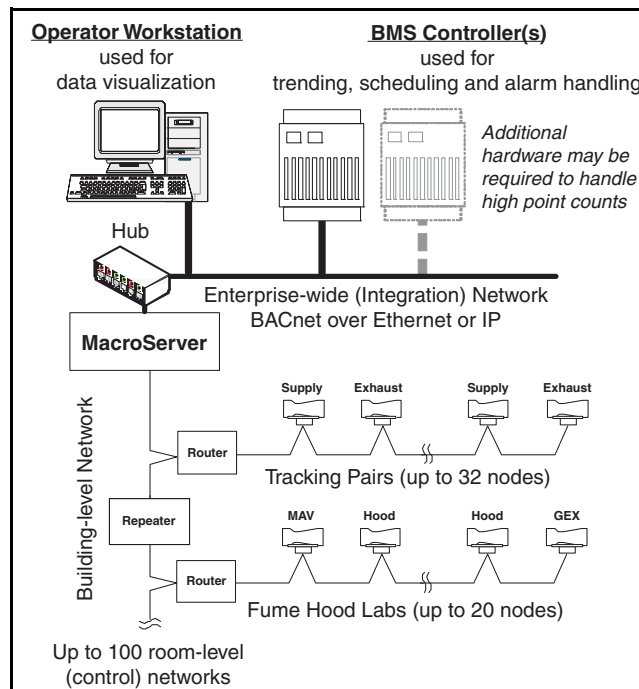

INSTALLATION

- The components of the MacroServer are indicated in the diagrams below.
- Choosing a location:
 - If practical, locate the MacroServer as close to the middle of the TP1250 channel as possible.
 - Locate the MacroServer within 328 feet (100 meters) of an Ethernet connection.
 - Locate near an analog phone outlet.
- The MacroServer must have a minimum clearance of 1 inch (2.54 cm) around each vented side.
- The disk drive must be oriented on the left or right side—not the top or bottom of the unit.
- Allow enough space to access the disk drive, power switch, etc.

IMPORTANT:

Place the MacroServer where it will be protected from:

- Direct sunlight, rain or moisture
- Corrosive gases or liquids
- Extreme temperatures
- Vibration, airborne dust or metallic particles

Notes:

1. It is highly recommended that the MacroServer be placed on an uninterruptible power supply (UPS) system capable of sustaining 300/345 watts of power over the duration of normal to emergency power changeover.
2. The MacroServer's operating system license is an embedded computer. It is *not* intended to be used as a workstation or desktop PC. A monitor, keyboard and mouse may be connected temporarily for setup and maintenance but *should not* be connected permanently.

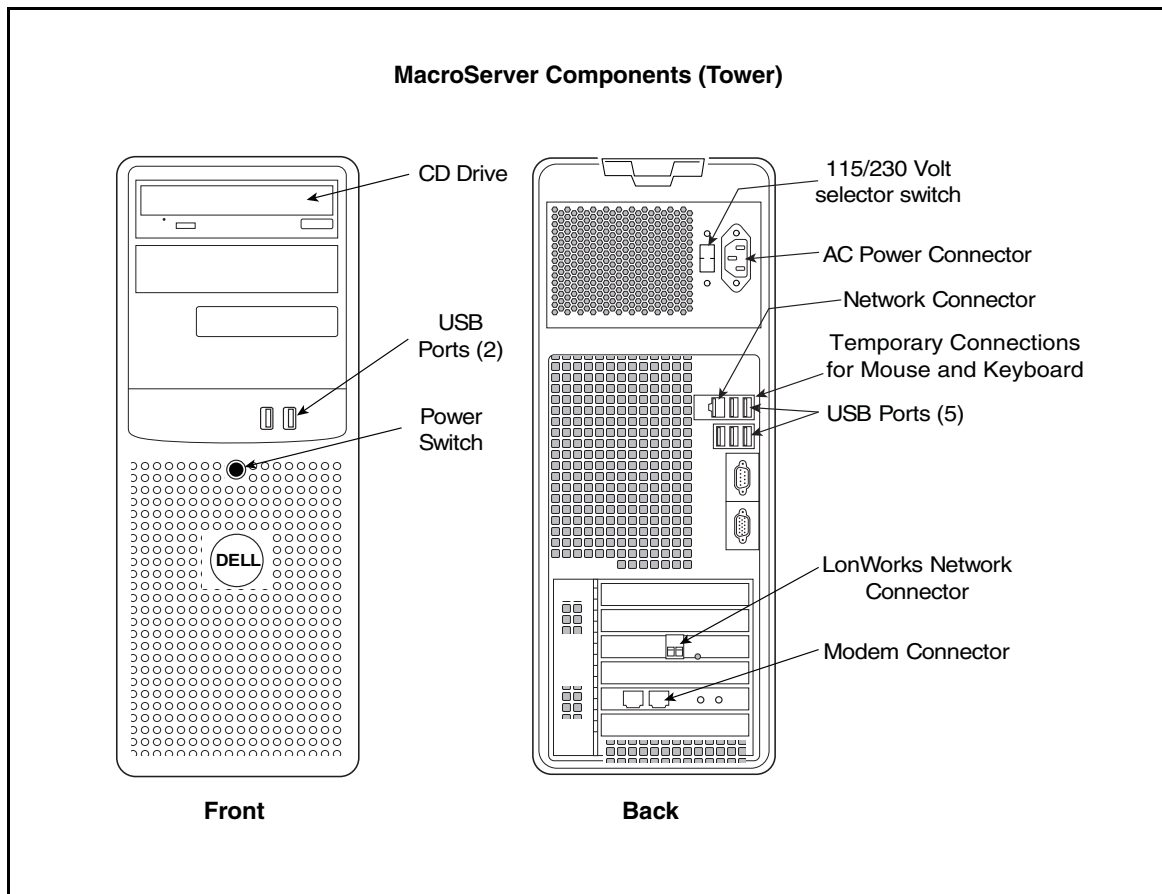

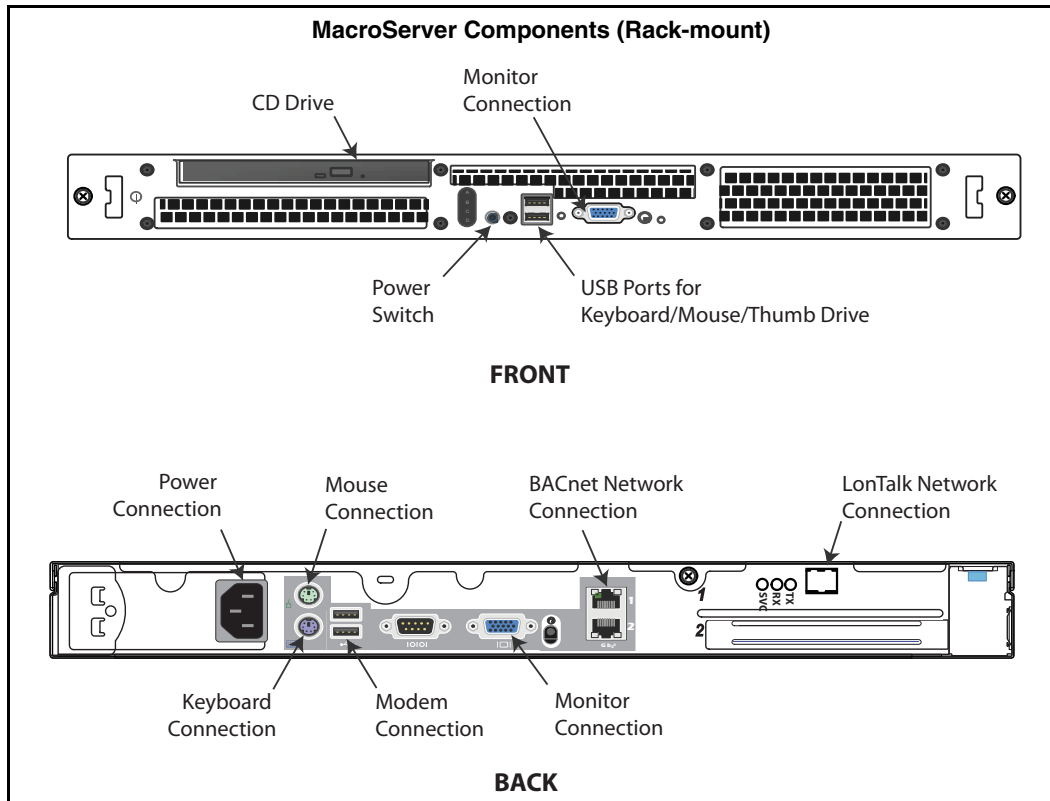

WIRING

Refer to wiring diagram on next page.

- For LonTalk communications:
 - Attach the TP1250 network wiring to the removable terminal block on the LonTalk Adapter Card (PCLTA).
 - The network cable must be a 22 AWG (0.65 mm) NEMA Level IV unshielded twisted pair. This is the only cable type tested and approved by Echelon.
 - Use a bus topology for connecting the routers (RTRXXX-XXX) at the top of the room-level networks.
 - Network segments may not exceed 425 feet (130 meters) in length. The network may be extended by adding repeaters (RPT100-XXX).
 - Verify that the number of routers and repeaters connected to the TP1250 network does not exceed 8 devices within a cable 52 feet (16 meters) in length (see 8 by 16 rule below).
- For BACnet communications:
 - Connect one end of the BACnet/Ethernet (CAT-5) cable to the RJ-45 connector on the back of the MacroServer (use the upper connector labeled BACnet on the Rack Mount chassis).
 - Connect the other end of the CAT-5 cable to any available building Ethernet connection or hub.
 - The network cable connecting the MacroServer to the network may not exceed 325 feet (100 meters).
- For modem communications:
 - Connect one end of the phone cable into the modular RJ-11 plug on the back of the MacroServer.
 - Connect the other end to a convenient analog phone wall outlet.
 - This connection may be shared with BMS equipment or a FAX line by using a Y splitter.
- Connect the MacroServer to an AC line voltage outlet.
 - A six-foot (1.8-meter) AC power cord is supplied with the MacroServer.
 - Verify the incoming line voltage and verify the voltage selector switch on the back of the MacroServer is set appropriately.
 - Connect the female power plug to the back of the MacroServer.

- Connect the male power plug into the AC outlet.

Note:

It is highly recommended that the MarcoServer be placed on an uninterruptible power supply (UPS) system capable of sustaining 300 watts of power over the duration of normal to emergency power changeover.

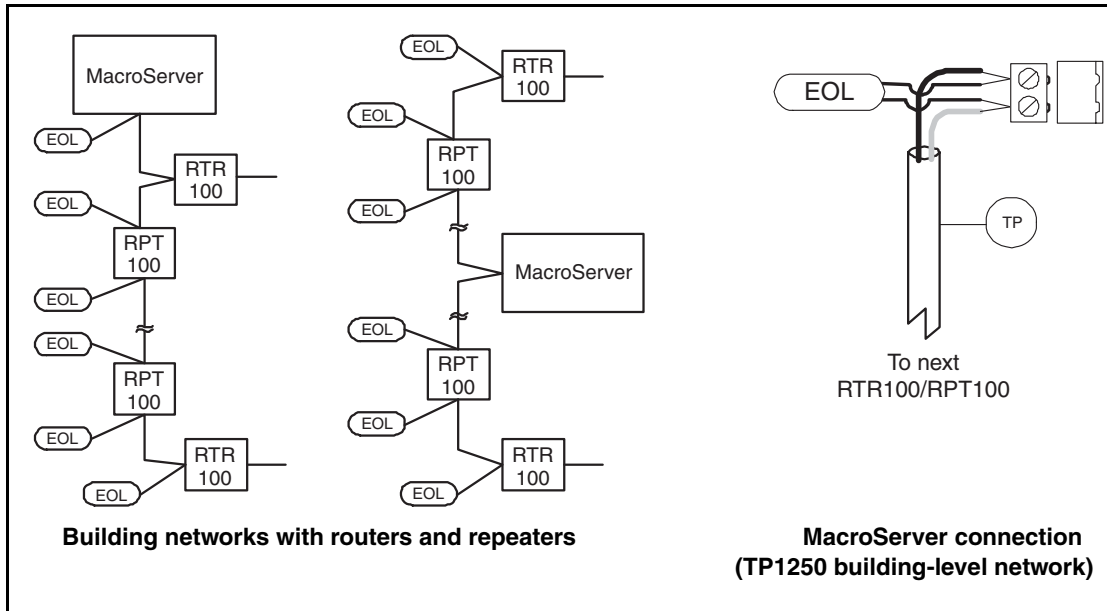

8 x 16 Rule for TP1250 Communications Channels

The 8 x 16 rule, simply stated, is that no more than 8 devices can be connected to the TP1250 building-level network over a length of cable less than 16 meters (52 feet) long. A high concentration of TP1250 devices may cause signal reflection, which will interfere with normal communications. In the Celeris, Theris and Traccel network, routers (the B side), repeaters and the server count as devices.

The diagram below shows acceptable node densities, along with those that could present problems.

Acceptable and Problematic Node Densities

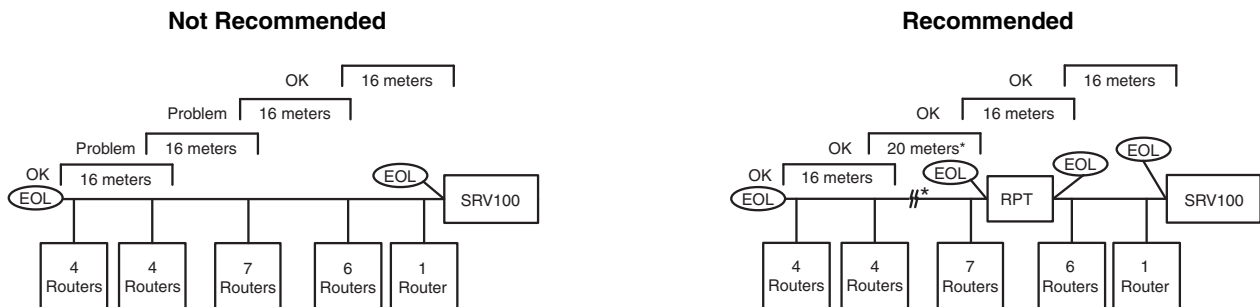

* To resolve issues when the 8 x 16 rule is violated, add more cable or add a repeater to break the network into two channels. Make sure that added cable does not extend the network beyond 425 feet (130 meters).

POINTS

See the table on the next two pages.

Points List

Recommended for Integration	Point Name	Description	Data Type	Writable?	Notes
Alarm Points (available on any node)					
	COM_FAILURE	Neuron chip has lost communications	Binary	Read only	
	SENSOR_FAILURE	Controller has detected a sensor failure on an input	Binary	Read only	
*	JAM_ALARM	The valve is unable to reach the commanded set point	Binary	Read only	
*	FLOW_ALARM	The pressure switch detected low static pressure	Binary	Read only	
	UI_1_ALARM	UI 1 is configured as an alarm input	Binary	Read only	
	UI_2_ALARM	UI 2 is configured as an alarm input	Binary	Read only	
	UI_3_ALARM	UI 3 is configured as an alarm input	Binary	Read only	
	DI_1_ALARM	DI 1 is configured as an alarm input	Binary	Read only	
Flow Points (available on any node)					
*	EFF_VLV_CMD	Effective valve flow command	Analog	Read only	
*	EFF_VLV_FLOW_FDBK	Effective flow feedback from valve	Analog	Read only	
Points Associated with a Hood Valve					
*	BROKEN_SASH_CABLE	Alarm indicating sash sensor cable is broken	Binary	Read only	
*	HOOD_OVERRIDE	Alarm indicating emergency override function on the fume hood monitor is active	Binary	Read only	
*	SASH_HEIGHT_ALARM	Alarm indicating sash input signal exceeds maximum sash height set point	Binary	Read only	
	AUXILIARY_AIR_SETPT	Tracking supply valve (MAV) flow set point	Analog	Read/write	
	INVERSE_GEX_SETPT	Tracking inverse general exhaust valve (GEX) set point	Analog	Read/write	
*	FACE_VELOCITY	Calculated face velocity	Analog	Read only	
*	SASH_OPEN_PERCENT	Calculated Sash Opening (0-100%)	Analog	Read only	
	SASH_SWITCH_STATE	Sash switch status (hood open or closed)	Binary	Read only	
*	USER_STATUS_STATE	Fume hood normal or standby (setback) mode	Binary	Read only	
Points Associated with Occupancy Control					
*	OCCUPANCY_CMD	Commanded occupancy state (occupied/unoccupied/standby)	Multi-state	Read/write	
	BYPASS_TIME_REMAIN	Time remaining for occupancy override mode (bypass)	Analog	Read only	5
*	EFF_OCC_MODE	Present occupancy state (occupied/unoccupied/standby/bypass)	Multi-state	Read only	
Points Associated with Emergency Mode Control					
	EMER_MODE_1	Alarm indicating emergency mode 1 is available	Binary	Read only	
	EMER_MODE_2	Alarm indicating emergency mode 2 is available	Binary	Read only	
	EMER_MODE_3	Alarm indicating emergency mode 3 is available	Binary	Read only	
	EMER_MODE_4	Alarm indicating emergency mode 4 is available	Binary	Read only	
*	EFF_EMER_MODE	Present emergency mode state (none, 1, 2, 3 or 4 active)	Multi-state	Read only	
*	EMER_MODE_CMD	Commanded emergency mode state (1, 2, 3 or 4)	Multi-state	Read/write	
Points Associated with Humidity Control					
*	EFF_HUMIDITY_SETPT	Effective humidity set point	Analog	Read only	
	HUMIDITY_DEMAND	Relative humidity command	Analog	Read only	
	HUMIDITY_SETPT	Humidity control set point	Analog	Read/write	
*	SPACE_HUMIDITY	Relative humidity present value	Analog	Read only	
Points Associated with Temperature Control					
*	OCC_COOL_SETPT	Cooling set point in the occupied mode	Analog	Read/write	
*	OCC_HEAT_SETPT	Heating set point in the occupied mode	Analog	Read/write	
*	UNOCC_COOL_SETPT	Cooling set point in the unoccupied mode	Analog	Read/write	
*	UNOCC_HEAT_SETPT	Heating set point in the unoccupied mode	Analog	Read/write	
	STNDBY_COOL_SETPT	Cooling set point in the standby mode	Analog	Read/write	
	STNDBY_HEAT_SETPT	Heating set point in the standby mode	Analog	Read/write	
*	EFF_TEMP_SETPT	Average of the cooling and heating set points	Analog	Read only	
*	OCC_TEMP_SETPT	Occupied temperature set point	Analog	Read/write	1
	OCC_TOFFSET_SETPT	Occupied temperature set point offset for cooling and heating	Analog	Read/write	1
*	AVG_SPACE_TEMP	Average of temperature sensor inputs used for control	Analog	Read only	
*	OFFSET_LVR_ENABLE	Enables or disables temperature offset lever	Binary	Read/write	
	OFFSET_LVR_PERCENT_OF_RANGE	Scaling value (0 to 100%) of the configured offset lever set point range	Analog	Read/write	
	AUX_TEMP_SETPT	Auxiliary temperature control set point	Analog	Read/write	
	EFF_AUX_TEMP_SETPT	Effective auxiliary temperature control set point	Analog	Read only	1, 2
	AUX_TEMP_CMD_STATE	Auxiliary temperature control demand output (on/off)	Analog	Read only	

Recommended for Integration	Point Name	Description	Data Type	Writable?	Notes
	AUX_TEMP_CMD_VALUE	Auxiliary temperature control demand output (0 to 100%)	Analog	Read only	
	COOLING_DEMAND	Cooling demand output (-100% = cooling)	Analog	Read only	
	HEATING_DEMAND	Heating demand output (+100% = heating)	Analog	Read only	
	DUCT_TEMP	Present value of duct sensor (not used for control)	Analog	Read only	
	DSCHRG_AIR_TEMP	Present value of discharge air temperature sensor	Analog	Read only	2
	DSCHRG_TEMP_SETPT	Discharge air temperature set point for thermal anticipatory control	Analog	Read only	2
	HEAT_DELIVERED	Present value of thermal energy (BTU) delivered to the space	Analog	Read only	2
*	TEMP_CTRL_MODE	Reports current temperature control state	Multi-state	Read only	
	HVAC_MODE_OVERRIDE	Allows BMS to override temperature control to one of eight states	Multi-state	Read/write	1
Points Associated with Zone Balance					
	DIVERSITY_ALARM	Total exhaust has exceeded diversity alarm threshold	Binary	Read only	
	OFFSET_SETPT	Zone offset set point	Analog	Read/write	
*	OFFSET	Calculated zone offset	Analog	Read only	
	OCC_MIN_SETPT	Occupied minimum ventilation flow set point	Analog	Read/write	
*	UNOCC_MIN_SETPT	Unoccupied minimum ventilation flow set point	Analog	Read/write	
*	TOTAL_ZONE_SUPPLY	Total of all networked and non-networked supply devices	Analog	Read only	
*	TOTAL_ZONE_EXHAUST	Total of all network and non-network exhaust devices	Analog	Read only	
	TOTAL_CNST_VOL_EXH_FLOW	Entered value of constant volume exhaust devices	Analog	Read only	4
	TOTAL_CNST_VOL_SUP_FLOW	Entered value of constant volume supply devices	Analog	Read only	4
	TOTAL_ADD_EXH_FLOW	Total of all hard-wired (non-networked) exhaust devices	Analog	Read only	1, 4
	TOTAL_ADD_SUP_FLOW	Total of all hard-wired (non-networked) supply devices	Analog	Read only	1, 4
Points Associated with Pressure Control					
*	SENSOR_FAILURE	Alarm indicating the pressure sensor is functioning or has failed	Binary	Read only	
*	ZONE_PRES_ALARM	Alarm indicating over or under pressure alarm condition	Binary	Read only	
*	EFF_PRES_SETPT	The set point to which the pressure control system will control	Analog	Read only	
*	ZONE_PRES_DIF	Present value of the measured zone differential pressure	Analog	Read only	
	ZONE_PRES_ABS	Present value of the measured zone absolute pressure	Analog	Read only	
	POC_STATE	Present state of progressive offset control function	Multi-state	Read only	
*	PRES_WARN_SETPT	Set point value for the over or loss of pressure warning function	Analog	Read/write	
*	PRES_ALRM_SETPT	Set point value for the over pressure alarm function	Analog	Read/write	
	FRZ_TIME_SETPT	Set point for duration of freeze mode if door remains open	Analog	Read/write	
	FRZ_TIME_REMAIN	Time remaining before freeze mode terminates	Analog	Read only	
	FRZ_MODE_OFFSET_SETPT	Set point for an alternate offset when the freeze mode is active	Analog	Read/write	
Network Inputs/Outputs (I/Os)					
	REMOTE_AO_0	User configurable analog output for non-network device	Analog	Read only	
	REMOTE_AO_1	User configurable analog output for non-networked device	Analog	Read only	
	REMOTE_AO_2	User configurable analog output for non-networked device	Analog	Read only	
	REMOTE_DO_0	User configurable digital output for non-networked device	Binary	Read only	
	REMOTE_DO_1	User configurable digital output for non-networked device	Binary	Read only	
	REMOTE_AI_0	User configurable analog input for non-networked device	Analog	Read/write	3
	REMOTE_AI_1	User configurable analog input for non-networked device	Analog	Read/write	
	REMOTE_AI_2	User configurable analog input for non-networked device	Analog	Read/write	
	REMOTE_AI_3	User configurable analog input for non-networked device	Analog	Read/write	
	REMOTE_AI_4	User configurable analog input for non-networked device	Analog	Read/write	
	REMOTE_DI_0	User configurable digital input for non-networked device	Binary	Read/write	3
	REMOTE_DI_1	User configurable digital input for non-networked device	Binary	Read/write	
	REMOTE_DI_2	User configurable digital input for non-networked device	Binary	Read/write	

Notes:

1. These variables are only available from TpVAV (Tracel Room Controller).
2. These variables are only available from a supply valve (MAV_TAC) with advanced temperature control.
3. Lab compact (LabCmpt) and Lab full support support a total of one remote AI and one remote DI.
4. Available on tracking pair (TP) and progressive offset control (POC) systems.
5. Bypass Time Remaining is not available on the SccLabCmpt or SocLabFull

MAINTENANCE

Once the MacroServer has been installed properly, it requires no ongoing preventive maintenance. If the MacroServer is installed in a dusty environment, the front and back should be vacuumed occasionally.

TROUBLESHOOTING

Remote troubleshooting may be accomplished using the internal modem. The Remote Desktop software, included as part of Windows XP on each server, allows Phoenix field service engineers to connect to Celeris, Theris and Traccel systems for remote interrogation, configuration, troubleshooting and software upgrades.

BACnet Functionality of the MacroServer

Data Sharing				
BIBBS Acronym	Description	BACnet Service	Initiate	Execute
DS-RP-B	ReadProperty-B	ReadProperty		x
DS-RPM-B	ReadPropertyMultiple-B	ReadPropertyMultiple		x
DS-WP-B	WriteProperty-B	WriteProperty		x
DS-WPM-B	WritePropertyMultiple-B	WritePropertyMultiple		x
DS-COV-B	Data Sharing-COV-B	SubscribeCOV		x
		ConfirmedCOVNotification	x	
		UnconfirmedCOVNotification	x	

Alarm and Event-Notification				
BIBBS Acronym	Description	BACnet Service	Initiate	Execute
AE-N-I-B	Alarm and Event-Notification Internal-B	ConfirmedEventNotification	x	
		UnconfirmedEventNotification	x	
AE-ACK-B	Alarm and Event-ACK-B	AcknowledgeAlarm		x
AE-ASUM-B	Alarm and Event-Alarm Summary-B	GetAlarmSummary		x
AE-INFO-B	Alarm and Event-Information-B			x

Device Management				
BIBBS Acronym	Description	BACnet Service	Initiate	Execute
DM-DDB-B	Dynamic Device Binding-B	Who-Is		x
		I-Am	x	
DM-DOB-B	Dynamic Object Binding-B	Who-Has		x
		I-Have	x	
DM-TS-B	TimeSynchronization-B	TimeSynchronization		x
DM-UTC-B	UTCTimeSynchronization			x
DM-LM-B	List Manipulation-B	AddListElement		x
		RemoveListElement		x
DM-DCC-B	Device Communications Control-B	DeviceCommunicationControl		x

Network Management				
BIBBS Acronym	Description	BACnet Network Layer Message	Initiate	Execute
NM-RC-B	Router Configuration-B	Who-Is-Router-To-Network	x	x
		I-Am-Router-To-Network	x	x
		I-Could-Be-Router-To-Network		
		Initialize-Routing-Table		x
		Initialize-Routing-Table-Ack	x	