

APPLICATIONS

Airflow Volume Control

Variable air volume (VAV) control schemes are commonly used for fume hoods, general exhaust, and room supply air. For typical fume hood applications, high-speed (< 1 second speed of response) actuation is required. The Celeris valve controller interfaces with our current fume hood monitors for control and monitoring. The Celeris platform provides room-level control functions in either standalone or integrated systems.

Tracking pair control (non-VAV applications), where make-up air control and an interface with the fume hood monitors are not required, low-speed electric actuation offers an economical solution for room-level ventilation, pressurization, temperature and humidity control in either standalone or integrated systems.

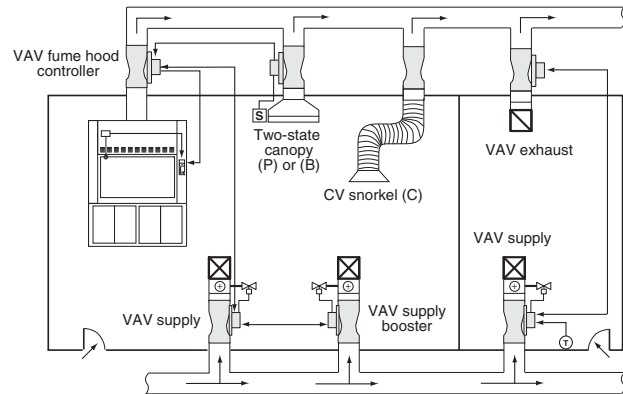

SPECIFICATIONS

Construction

- 16 ga. spun aluminum valve body with continuous welded seam
- Valve bodies available as uncoated aluminum or with corrosion-resistant baked phenolic coatings
- Composite Teflon® shaft bearings
- Spring grade stainless steel spring and polyester or PPS slider assembly
- Supply valves* insulated with 3/8" (9.5 mm) flexible closed-cell polymer-based foam. Flame/smoke rating 25/50. Density is 1.5 lb/ft³ (24.0 kg/m³)

Operating Range

- 32-122 °F (0-50 °C) ambient
- 10-90% non-condensing RH

Performance

- Pressure independent over a 0.3"-3.0" WC (75-750 Pa) drop across valve
- Volume control accurate to ±5%, 5 cfm of airflow command signal
- No additional straight duct runs needed before or after valve
- Available in flows from 35-5600 cfm (60-9514 m³/hr)
- Response time to change in command signal:
 - <1 second (control type M and N)
 - <1 minute (control type L)
- Response time to change in duct static pressure: <1 second

Pneumatic Actuation

- (Not available with the 14-inch valve)
- 20 psi (-0/+2 psi) with a 20 micron filter main air required
- Compressor sizing: Accel II Valves are not continuous air-consuming devices. For compressor sizing, use:
 - single and dual valves: 10 scim
 - triple and quad valves: 20 scim

Sound

Designed for low sound power levels to meet or exceed ASHRAE noise guidelines.

Power

24 Vac (±15%) @ 50/60 Hz

Power Consumption

- Singles/Duals *per valve*
- Low-speed Electric: 10 VA
 - High-speed Electric: 70 VA
 - Pneumatic: 10 VA

Notes:
1. All power consumption VA ratings listed here are based on fully-loaded I/O.

I/O

- Available for connecting field devices:
- 3 universal inputs. Accepts volt, mA, ohms or NTC 2 or 3 thermistor signals.
 - 1 digital input
 - 2 analog outputs. Provides volt or mA signals.
 - 1 digital output (Type C, 1 amp @ 24 Vac/Vdc)
 - Input accuracy: Voltage, current, resistance: ±1% full scale
 - Output accuracy
 - 0 to 10 Vdc: ±1% full scale into 10 kΩ minimum
 - 4 to 20 mA: ±1% full scale into 500 Ω +0/-50 Ω

Agency Compliance

- CSA
 - CE
 - FCC
- Room-level communications: FTT-10, 78 KB, bus topology, LonTalk™ network
 Building-level communications: TP-1250, 1.2 MB, bus topology, LonTalk™ network

CE, SB, See wiring diagrams

* Not applicable to CVV series.
 Teflon is a registered trademark of DuPont Company.
 LonWorks is a registered trademark of Echelon Corporation.

FEATURES

FEATURE/OPTION	VAV (EXV/MAV)		
	L	N	M
Control type			
Actuator type	Low-speed electric	Pneumatic*	High-speed electric
Flow feedback signal	✓	✓	✓
Failsafe	Last Position	NO/NC	NO/NC/Last Position
Factory-insulated valve body (supply)	✓	✓	✓
Field-adjustable flow	✓	✓	✓
Flow alarm via feedback circuit	✓	✓	✓
Flow alarm via pressure switch	Option	Option	✓
Low noise diffuser construction†	✓	✓	✓

All valves include pressure independent controller, factory-calibrated position controller.
 †Accel II valves are designed to reduce sound over all frequencies, but significantly target the lower bands (125-500 Hz) to help eliminate the need for silencers.
 *The pneumatic actuator is not available for the 14-inch valve at this time.

FCC COMPLIANCE STATEMENT

This device complies with part 15 of the FCC Rules. Operation is subject to the following two conditions:
 1. This device may not cause harmful interference.
 2. This device must accept any interference received, including interference that may cause undesired operation.

TABLE OF CONTENTS	
Ordering Guide.....	2
Typical Valve Controllers and Options	3
Points and Wiring	3
Transformers.....	5
Power Conductor Sizing.....	6

ORDERING GUIDE

MAV A 1 12 L - A M E H O - SFB REI

VALVE FAMILY

EXV = Celeris exhaust valve
 MAV = Celeris supply valve (comes standard with insulation)

VALVE CONSTRUCTION

A = Body and cone uncoated aluminum; uncoated 316 stainless steel shaft
B = Body and cone with baked-on phenolic coating; PFA-coated 316 stainless steel shaft
C = Body and cone with baked-on phenolic coating; hardware with titanium or baked-on epoxy phenolic coating; PFA-coated 316 stainless steel shaft
D = Body and cone with PVDF coating; hardware with PVDF or baked-on epoxy phenolic coating; PFA-coated 316 stainless steel shaft; *see Note 1*

NUMBER OF VALVE BODIES

F = Single valve body with welded circular flange
1 = One valve body no flange
2 = Two valve bodies as one unit (dual); 10", 12", and 14" valves only

VALVE SIZE

08 = 8" valve (7.88"/200 mm actual diameter)
10 = 10" valve (9.67"/246 mm actual diameter)
12 = 12" valve (11.84"/301 mm actual diameter)
14 = 14" valve (13.88"/353mm actual diameter)

FLOW/PRESSURE OPERATING RANGE

L = Low pressure operation; pressure independent over a range of 0.3 to 3.0" WC (75 to 750 Pa), associated pressure switch trips at 0.2" WC
 See Standard Valve Flow/Pressure Operating Range table below

VALVE OPTIONS

EVI = Exhaust valve with insulation blocks and insulation
IBO = Insulation blocks only, no insulation
PSL = Pressure switch, low limit
REI = Remote electronics; indoor applications only; *see Note 2*
REO = Remote electronics; outdoor applications only, pneumatic actuation only; *see Note 3*
WRE = Weather resistant electronics; outdoor applications, electric actuation; *see Note 4*
SFB = Square flanges on both ends of single-body valves; *see Note 1*
SFX = Single square flange mounted on either the exhaust inlet or supply discharge; *see Note 1*

FAIL-SAFE POSITION

C = Normally closed
O = Normally opened
Z = Fails to last position

VALVE ORIENTATION

H = Horizontal
U = Vertical upflow
D = Vertical downflow

VALVE CONTROLLER DESIGNATION

E = Electronic controller
H = Hood exhaust valve with pressure switch; *see Note 5*

CONTROL TYPE

I = IP54 low-speed electric; *only available on single-body valves in sizes 08, 10, 12*
L = Low-speed electric
M = High-speed electric
N = Pneumatic

VALVE DESIGN

A = Conical-shaped diffuser (Accel II)

FLOW/PRESSURE OPERATING RANGE FOR STANDARD VALVE DESIGNS

Designation	Size	Operating Range in CFM (m3/hr)		Pressure Drop Across Valve
		Single	Dual	
L = Low Pressure	08"	35-500 (60-845)	—	0.3-3.0" WC (75-750 Pa)
	10"	50-550 (85-930)	100-1100 (170-1860)	
	12"	90-1050 (155-1780)	180-2100 (310-3560)	
	14"	200-1400 (340-2375)	400-2800 (680-4750)	

NOTES:

- Construction D is ONLY available in single-body valves (Number of Bodies = F or 1) WITHOUT square flanges (Options SFB or SFX). Rectangular plates can be purchased as special products to field assemble two, three or four single-body round-flanged valves into multi-body configurations. For sizes 08, 10, and 12 only.
- Option REI: Remote Electronics, Indoor installations ONLY. The distance to the valve controller is limited to:
 - 75 feet (22.8 meters) of pneumatic tubing for pneumatic actuators (Control Type = N).
 - 40 inches (1 meter) of 18 gauge cable for high-speed electric actuators (Control Type = M).
 - 150 feet (45.7 meters) of 22 gauge cable for low-speed electric actuators (Control Type = L or I).
- Option REO: Remote Electronics, Outdoor installations ONLY. Limited to PNEUMATICALLY actuated valves ONLY (Control Type = N).
 - HORIZONTAL orientation ONLY.
 - Includes: sealed Vpot, small weather-resistant NEMA 3R box mounted on base channel for others to connect Vpot cables, and a valve controller in an enclosure that has been disconnected from the base channel and shipped in the same box as the valve.
 - Maximum distance between remote mounted enclosure and valve is 75 feet (22.8 meters), the maximum allowable length of pneumatic tubing.
 - REQUIRES use of a dog house enclosure, provided by others, to protect valve from the elements and maintain temperature and humidity conditions within Phoenix's specifications.
- Option WRE: Weather Resistant Electronics, outdoor installations. Applies to ELECTRICALLY actuated valves with sufficient IP ratings only - Control = I or M for single-body valves; Control = L or M for multi-body valves.
 - HORIZONTAL orientation ONLY.
 - Includes: sealed Vpot and large weather-resistant IP66 box mounted on base channel that houses the controller and all electric connections to/from it.
 - When used in Low-Speed Electric applications for 08", 10", and 12" single-body valves, WRE must ALSO be ordered with Control Type I (IP54 actuator) in place of the standard Control Type L.
 - When used in High-Speed Electric applications, standard actuators are sufficient (Control Type = E or M) since they are IP56 actuators.
 - REQUIRES use of a dog house enclosure, provided by others, to protect valve from the elements and maintain temperature and humidity conditions within Phoenix's specifications.
- Celeris Hood valves cannot have Low Speed actuators (Control Type = L or I).

VALVE CONTROLLERS AND OPTIONS

Valve Controller Designation

Controller Type E—Suitable for supply, make-up air, and general exhaust valve applications.

Controller Type H—Suitable for fume hood applications and includes a pressure switch for alarming.

Valve Options *(components added to enhance a valve's functions)*

Single square flange (SFX)—Provides a single connection from a round single body valve to a square duct (on the inlet of single body exhaust valves; discharge of single body supply valves). typically used in Neutralizer™ applications.

Two square flanges (SFB)—Transitions each end of a single body valve from a round to square duct.

Pressure switch (PSL)—Detects low static pressure across the valve. Installed on non-hood exhaust valves to provide low static pressure alarm monitoring.

POINTS AND WIRING

NOTE: See submittal wiring diagram for project-specific details.

Celeris Valve Controller

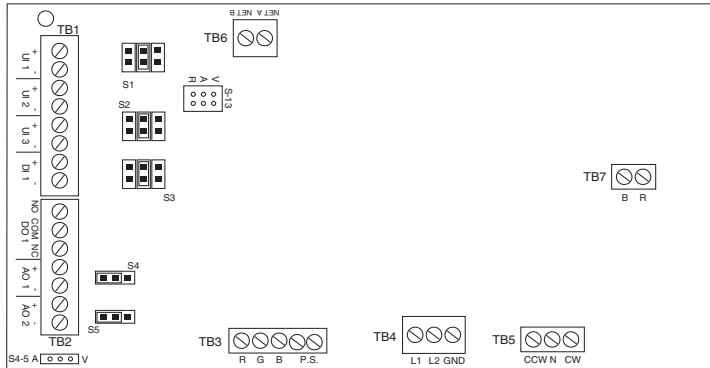

NOTES:

- Power—14 AWG (Controller Type M).
High-speed electric valves must be connected in a star configuration.
- Power—18 AWG (Controller Type L).
- Control signal—22 AWG multi conductor, twisted pair
- Communication—22 AWG level 4; 16 AWG Belden 8471 (or equivalent)
- Each termination block (except TB3, 5 and 7) uses a depluggable connector with screw-down terminations for ease of installation.

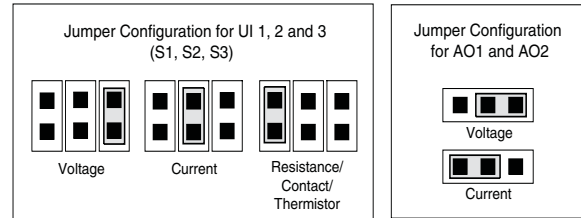

TERMINAL BLOCKS—CELERIS VALVE CONTROLLERS

Terminal Block	Typical Function	Number of Terminations
TB1	Input connections	8
TB2	Output connections	7
TB3	vPot and pressure switch	5
TB4	Power (24 Vac input)	2
TB5	Actuator (control type L only)	2
TB6	Communication (FTT-10)	2
TB7	Actuator (control type M only)	2

Typical Wiring Diagrams

Hood Applications

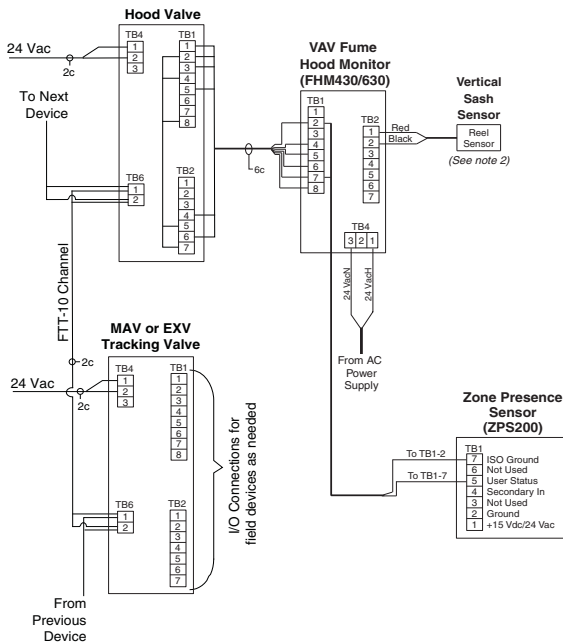

Tracking Pair Applications

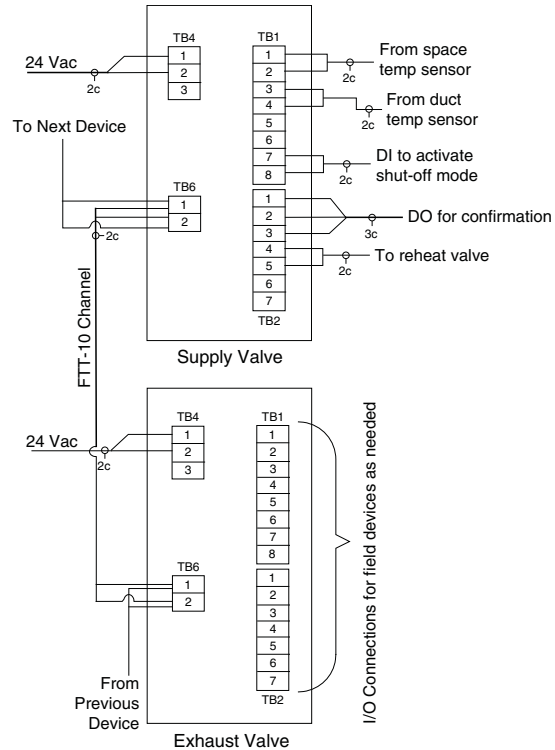

Network Wiring

Room-level Network

Echelon Corporation has tested and approved 5 cables types for use with the FTT10 communications transceiver. Based on availability, cost and maximum distance limitations, we have focused our recommendation to two cable types:

- Generic NEMA level 4 cable, 22 AWG (0.65 mm)*
- Belden 8471, 16 AWG (1.3 mm) cable (or equivalent)

NOTE: Level 4 cable specified by Echelon as originally defined by the NEMA differs from the Category 4 specification proposed by the Electronic Industries Association/Telecommunication Industry Association (EIA/TIA).

The cables Phoenix Controls recommends are stranded, two-conductor, twisted-pair (TP) without a shield. A shield, or drain wire, is not required for Celeris communications wiring and should not be used. Both of these cables are available from multiple sources either solid or stranded, in plenum and non-plenum rated versions.

- If two conductors are to be placed in a terminal opening, twist the bare conductors prior to inserting these in the terminal opening.
- If a wall-mounted sensor with a communications jack is used, the connections to the jack must be treated as either a bus connection or an EOL connection.
- While the room-level communications wiring is not polarity sensitive, it is recommended that a consistent color-coding and polarity convention be followed.
- Each terminal on the terminal block will accommodate up to two 16 AWG (1.3 mm) stranded conductors.
- Communications connections are to be made following a bus or daisy chain topology.
- Two end-of-line (EOL) terminators must be installed, one at each end of the room-level network.

Maximum Cable Lengths

- When using Level 4 cable operating in a bus topology, the maximum cable length is 4500 feet (1370 meters).
- When using 16 AWG cable operating in a bus topology, the maximum cable length is 8800 feet (2680 meters).

Phoenix Controls Wiring Recommendations

- Use cables recommended by Phoenix Controls.
- Stranded wire is strongly recommended for ease of installation.
- Follow good wiring practices:
 - Do not run the communications cable in the same conduit or wire way as the power cables.
 - If the communications cables must cross power cables, it is best to do so at a 90-degree angle.
 - Shield or drain wires, if present, should be wrapped with insulating tape to prevent contact with exposed conductors or contacts.
 - Maintain a consistent color code or polarity all the way through the wiring system.
 - All connections must meet the requirements of an NEC Class 2 circuit.
 - Local and national electrical codes take precedence.

TRANSFORMERS

The Celeris valve controller requires the use of a step-down transformer (either 120/24 volt or 240/24 volt). Any transformer used to power Celeris valve controllers must meet the requirements of an NEC Class 2 circuit.

- The secondary transformer must be limited to a maximum of 30 Vac.
- Secondary power shall be current limited with either internal circuit breaker protection or with a four-amps slow-blow fuse, in accordance with NEC Class 2 power requirements.

Phoenix Controls offers the following recommendations; however, designers, installers and owners should always consult their national and local electrical codes before selecting transformers for their systems.

- Transformers should not exceed 100 VA. Use multiple transformers, rather than larger transformers, when more than 100 VA is required.
- Each pressurization zone should have either a dedicated single-phase primary circuit or a secondary circuit disconnect.
- If an earth ground is provided, it should not be connected to the Celeris valve controller, even though there is a three-terminal connector on the controller board.

NOTE: AC line voltage polarity must be maintained on all Celeris valve controllers and AC powered ancillary devices.

Transformer Sizing

To size a transformer, all of the VA loads for the circuit must be totaled. This table outlines the power ratings of Celeris products and related outside purchased equipment. Use these values to size the power transformers for the Celeris system.

Celeris Valve Controller		
Control type L (low-speed electric)	Single/dual valve body	10 VA
Control type M (high-speed electric)	Single/dual valve body	70 VA
Control type N (pneumatic)	Single/dual valve body	10 VA
External Devices		
Router/repeater modules		2 VA
Sensor	Approved thermistor	0 VA
Heating valve	Belimo LM24 (2-state)	3 VA
Heating valve	Belimo LM24SR (propor)	4 VA
Each 4-20 mA device	Example: transducers	0.5 VA

Power Conductor Sizing

For low-speed valves in a bus configuration; as a rule of thumb for loads up to 100 VA, use 18 AWG cable with a maximum length of

110 feet (33 meters) between the transformer and the last daisy-chained device.

For a more exact length per load number, refer to this chart. For high-speed valves in a star configuration, refer to the 14 AWG column of this chart.

Maximum wire length (in feet) given a wire gauge and VA delivery by transformer					
VA Delivered	Wire Gauge				
	14 AWG	16 AWG	18 AWG	20 AWG	22 AWG
10	2880	1743	1095	695	433
20	1440	871	548	347	216
30	960	580	365	213	144
40	720	435	274	174	108
50	576	348	219	139	86
60	480	290	182	115	72
70	411	249	156	99	61
80	360	217	136	86	54
90	320	193	121	77	48
100	288	174	110	69	43

NOTE: Control Type M (high-speed electric actuation) must use at least 14 AWG. Wired in a star or home run configuration (not daisy-chained).