

Phoenix Controls Local Display Unit (LDU) is a networked-based user interface panel intended to display data and/or edit set point variables for vivariums, biocontainment or laboratory spaces maintained by the Celeris® Environmental Control System. The LDU may be flush or surface mounted on a variety of electrical enclosures. It is intended to be installed in corridors outside of critical environments to provide users with information related to operating conditions inside the space. Using a 128 x 128 pixel graphical display, the LDU can display up to five parameters simultaneously. Each parameter includes a 16-character user defined description and the present value, including units of measure.

The LDU connects to the Celeris room-level network and may be used to display flow, temperature, humidity, control or set point variables available on the Celeris network.

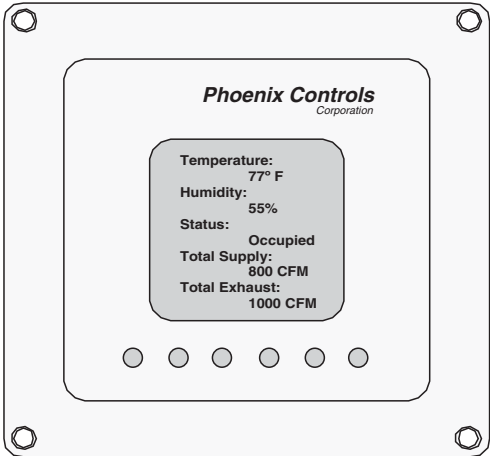

Local Display Unit (LDU).

SPECIFICATIONS

Power

Voltage
24 Vdc/Vac; ±15%, 50/60 Hz

Consumption
8 VA (13 VA maximum)

Protection
1.5 amp auto reset fuse

Environmental

Operating Temperature
32-158° F (0-70° C)

Storage Temperature
-4-158° F (-20-70° C)

Temperature Relative Humidity
0-90%, non-condensing

General

Processor
Neuron® 3158, 8 bits, 10 MHz

Memory
• Flash 64 K (APB applications)
• Flash 64 K (storage)

Clock
Real-time clock chip, accurate to ±1 minute per month

Battery

CR 2032 Lithium battery; retains clock time for 1 year with no power applied

Communication

LonTalk® protocol

Transceiver

TP/FT-10, 78 kbps

Enclosure

- Material: ABS resin
- Color: Off-white
- Dimensions:
 - Flush mount: 6" x 6" x 1.5" (151 x 151 x 38 mm)
 - Din rail mount: 4.5" x 4.5" x 1.5" (113 x 113 x 38 mm)
- Weight: 0.73 lbs (0.33 kg)

Display

- Type: Backlit LCD
- Definition:
 - 128 x 128 pixels
 - 10 lines (5 variables) x 13 characters
- Display area: 2.1" x 2.1 (5.5 cm x 5.5 cm)

FEATURES

- **Easy to navigate display** with 5 parameters per window and up to 50 windows
- **Password protected**—Read-only and read/write access
- **Supports all Celeris data**
 - **Flow**—Valve flow and set point, total supply and exhaust, offset and offset set point
 - **Temperature**—Present values and occupied and unoccupied set points
 - **Humidity**—Present value and set point
 - **Occupancy**—Displays present state, minimum ventilation and temperature set points, and/or override current state
 - **Emergency modes**—Display present state, and/or override current state
 - **Alarms**—Display current state of any alarm on any valve controller/hood
 - **Ancillary devices**—Display scaled values from non-networked analog or digital devices
- **Flexible mounting**
 - **Flush mount**—Protrudes less than 0.27" (6.9 mm) from wall surface
 - **Surface mount**—Mounts to standard electrical enclosures, as well as a DIN rail

ORDERING GUIDE

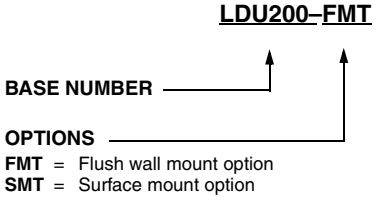

TABLE OF CONTENTS

Specifications 1

Features..... 1

Ordering Guide 1

Applications..... 2

Installation..... 3

Dimensions..... 4

Keyboard Layout and Navigation..... 5

Wiring 5

Maintenance 6

Troubleshooting..... 6

APPLICATIONS

The LDU provides a local user interface for the spaces being controlled and monitored by the Celeris system. Any point available on the Celeris room-level network may be displayed on the LDU. Both read-only and read/write set points may be mapped to the LDU. The LDU Configuration plug-in allows set points to be displayed as read only or password protected so that only users with the read/write password can make changes to set point values. The LDU Configuration plug-in may also be used to set values to display alternate units of measure, an alternate enumeration type (i.e., ALARM/NORMAL, ON/OFF, ACTIVE/INACTIVE) and set the number of decimal places to be displayed (up to 3 places—0.000).

The LDU200 menus and data display are organized in a series of "screens." Screens include the main menu, a number of local set-up screens, and up to 50 data screens. Each data screen has a user defined label that may be up to 13 characters in length and includes up to 5 data points each with a user defined label that may be 16 characters in length. When a data screen is selected, the LDU reads all of the points on that particular screen and continues to update values at a configurable interval between 5 and 60 seconds. To minimize network traffic, only the points on the active screen are updated. After a configurable interval, the LDU will revert back to the main menu.

A six-button keypad allows for navigation through the various screens and editing of values. Keys include cursor navigation—UP, DOWN, LEFT and RIGHT—as well as an ENTER and EXIT key for moving in and out of the menus. An on-board, real-time clock provides a local indication of time/date. The time sync variable is the only variable intended to have bindings that cross routers.

The Celeris system allows the user to connect non-networked devices, such as temperature values or alarm contacts from ovens or freezers, to available analog or digital inputs on any valve controller and mapping these points for monitoring or control. These values may also be mapped to the LDU for local monitoring purposes.

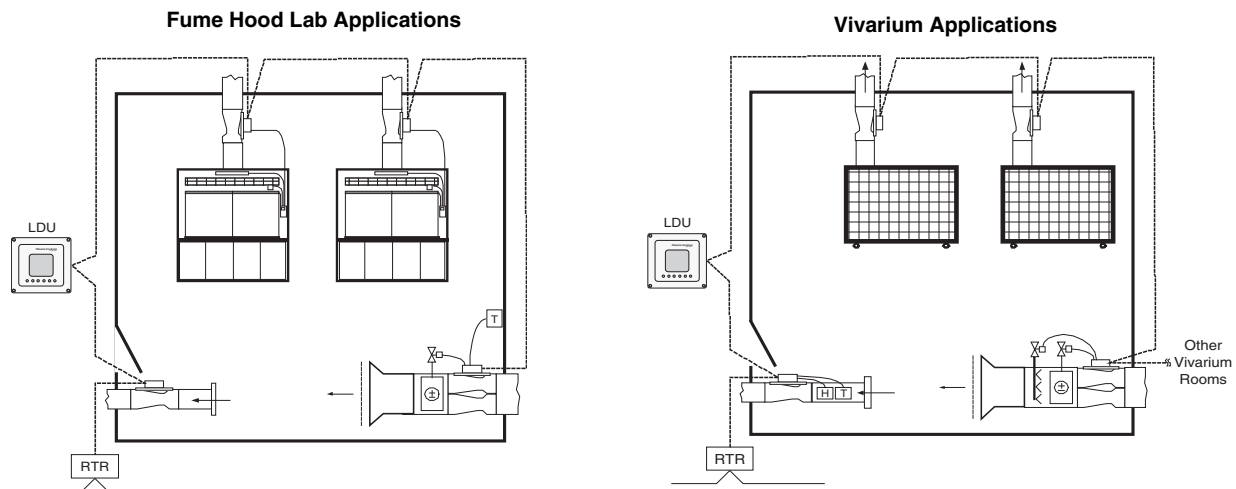

Typical points from a lab system:

- Space temperature and temperature set points
- Total zone supply and exhaust flow values
- Offset and offset set point
- Individual valve flows and flow set points
- Occupancy status
- Emergency mode status
- Fume hood data
- Analog or digital values from non-networked devices connected to Celeris valve controller for monitoring or control

Typical points from a vivarium space:

- Space temperature and temperature set points
- Space humidity and humidity set point
- Total zone supply and exhaust flow values
- Constant volume supply and/or exhaust values
- Offset and offset set point
- Individual valve flows and flow set points
- Occupancy status
- Analog or digital values from non-networked devices connected to Celeris valve controller for monitoring or control

INSTALLATION

The LDU200 is available with two mounting options: surface mount and flush mount.

- The LDU200-SMT is designed to mount onto a flat surface using standard electrical junction box mounting screw locations. There are three possible mounting scenarios for the standard casing: North American electrical box, European electrical box and DIN rail.
- The LDU200-FMT is designed to be flush mount into a wall or panel and is secured using 4 #4 or #5 wood screws.

The LDU200-SMT is shipped in an assembled manner in order to protect the electronic components. Detach the display panel of the device by gently pressing on the panel as the arrows indicate in Figure 1 and pulling the front panel outward simultaneously.

Power and communications cables enter from the rear of the enclosure. Pull cables 6" out of the wall.

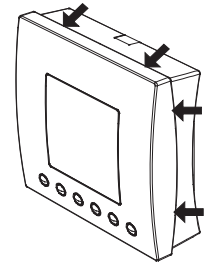
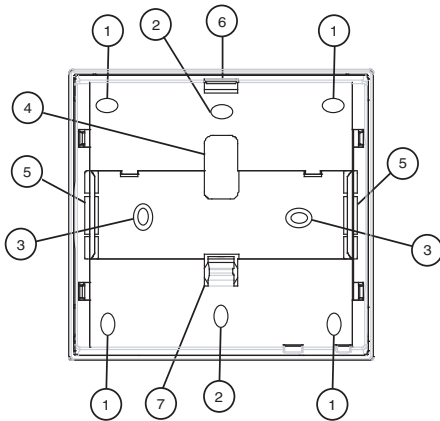

Fig. 1 Detaching the LDU display panel.

Surface Mount Option

1. Select the installation location; the wall must be flat and clean. Detach the display panel of the device by gently pressing on the panel as the arrows indicate in Figure 1 and pulling the front panel outward simultaneously.
2. Secure the LDU200 to the surface with at least 2 mounting screws.



Legend:

1. Holes for 4" x 4" North American electrical box mounting.
2. Holes for 2" x 4" North American electrical box mounting.
3. Holes for standard European electrical box.
4. Wire exit space for North American and European mounting.
5. Break-off tabs for DIN rail mounting.
6. Break-off tab for wire exit in DIN rail mounting.
7. Clip for DIN rail mounting.

Fig. 2 LDU with surface mount (back view).

DIN Rail Mount Option

The EC-DISPLAY can be mounted on a DIN rail as shown in Figure 3. To do so, follow these simple steps:

1. Break off tabs 5 (see Figure 2). This is the path of the rail.
2. Break off tab 6 (see Figure 2). This is the wire exit.
3. Detach the display panel of the device by gently pressing on the panel as the arrows indicate in Figure 1 and pulling on the front panel simultaneously.
4. Slide DIN rail into rear panel using clip 7 (see Figure 2).

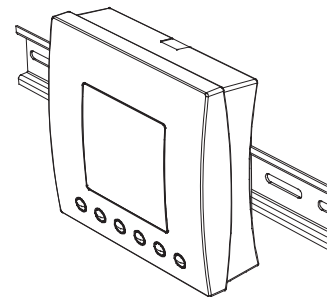

Fig. 3 LDU with DIN rail mount.

Flush Mount Option

1. Select the installation location; the wall must be flat and clean. Detach the front display panel from the device by gently pushing outward on the rear openings as shown in Figure 4. Do not reinsert the display panel until wiring is complete.
2. Prepare area where the LDU will be mounted by cutting a 4.75" (120.7 mm) opening with 4 holes for #4 screws (see Figure 7).
3. Place power and communications cables through opening 4 in the rear of the flush mount housing (see Figure 2) and mount the housing using 4 screws.
4. Proceed to wire the LDU.

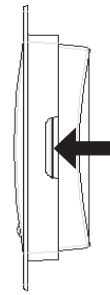

Fig. 4 Detaching display panel from LDU with flush mount.

DIMENSIONS

All dimensions are in inches (millimeters). Allow 0.5" (12.7 mm) behind the LDU for exiting cables.

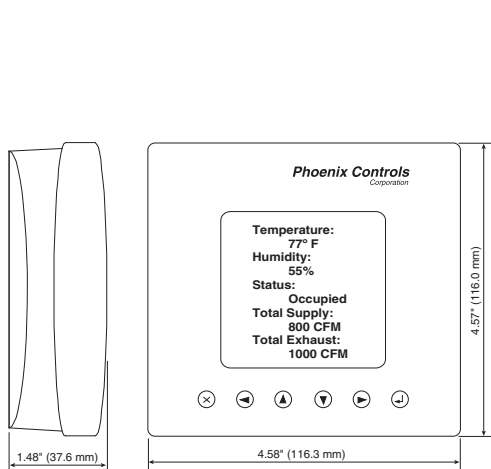

Fig. 5 LDU with surface mount option (LDU200-SMT).

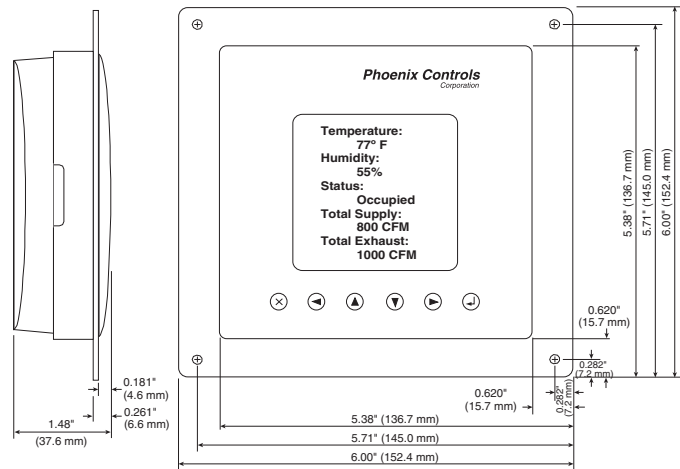

Fig. 6 LDU with panel mount option (LDU200-FMT).

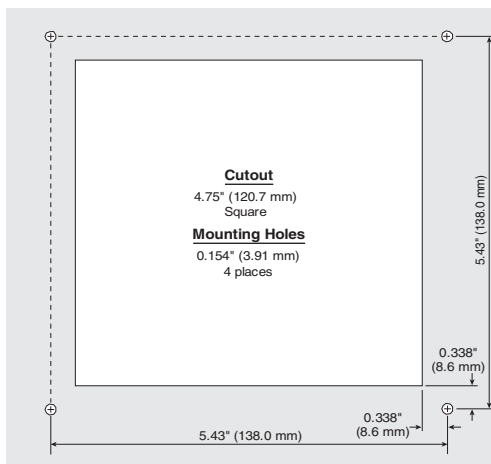

Fig. 7 LDU cutout with mounting holes.

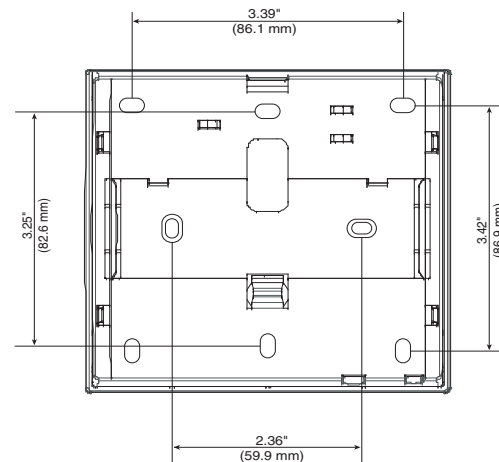
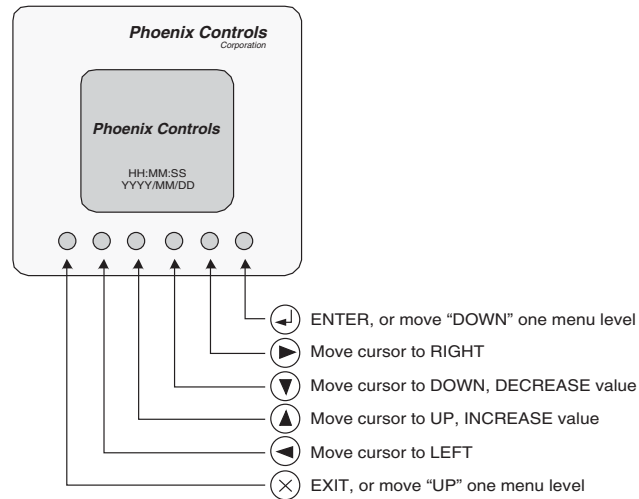

Fig. 8 LDU (back view).

KEYBOARD LAYOUT AND NAVIGATION



WIRING

1. Strip network wires and connect to the terminals marked Net A and Net B.
2. Strip power supply wires and connect to the terminals marked -24 Vac/Vdc and +24 Vac/Vdc.
NOTE: When sharing power sources with other devices, a consistent polarity for the AC wiring should be maintained (L1 to L1 and L2 to L2).
3. Reattach the front panel of the device by pressing gently until you hear a click (buttons should be below screen).

□	⊗	- Net B
□	⊗	- Net A
□	⊗	- 24V AC/DC
□	⊗	+ 24V AC/DC

4. Plan the placement of cables for communication and power.
 - Power and network cables must be placed so as to avoid the effects of ambient noise. Ambient noise is generated by many building components (e.g., lighting ballasts, electric motors, electronic power converters).
 - Analog type cables for power, communication, inputs and outputs must be separated from other types of cables.

Cable Selection

- Power—Minimum wire size 18 AWG
- Network—Minimum wire size 24 AWG
- Cables should be twisted pair, unshielded. (See Phoenix Controls *Laboratory Engineering Guide* or Phoenix Tools for a complete list of acceptable wire and cables.)

MAINTENANCE

The only user serviceable component of the LDU is periodic replacement on the battery used to retain real-time clock data (time and date). The life expectancy of the lithium battery is 5 years under normal use. The battery will maintain proper time and date for one year with no power applied. The battery is not used to back-up or retain configuration data.

The battery used in the LDU is a CR 2032. It is available from any local or regional electronics, office supply or drug-store. Typical part numbers:

Description	Vendor	Part Number
3 V lithium battery	Newark Electronics	93B2632
	DigiKey Electronics	P189-ND
	Radio Shack	23-132
Flush mount replacement case	Phoenix Controls	540-200-002
Surface mount replacement case	Phoenix Controls	540-200-003

TROUBLESHOOTING

Problem	Possible Causes	Solutions
1. The LCD display does not illuminate.	<ul style="list-style-type: none"> A. There is no input power. B. A fuse is blown. 	<ul style="list-style-type: none"> A. Verify the wiring terminations— Check that the line voltage is within specifications. B. Check the external fuse.
2. The values are not updating on the display.	<ul style="list-style-type: none"> A. The network wiring has not been connected properly. B. The device has not been commissioned. C. The points are either not mapped to the LDU or mapped incorrectly. 	<ul style="list-style-type: none"> A. Verify the wiring terminations. B. Open the LonMaker database and verify the status of the device. Commission if required. C. Open the LonMaker database. Then launch the LDU Configuration plug-in to verify that the point mapping is complete and to the proper device, function and point.
3. The set point values cannot be written to.	<ul style="list-style-type: none"> A. Verify that the W symbol on the LDU display is visible, which indicates that the point is writeable. B. If the point is known to be an input variable and the W symbol is not visible, a configuration error is likely. 	<ul style="list-style-type: none"> A. If the symbol is not visible, open the LonMaker database, launch the LDU configuration plug-in and verify that in the Point Set-up dialog box, the Write Enable box is checked. If the symbol is visible, open the LonMaker database, launch the Celeris Configuration plug-in and verify that the Use Fixed Set Point box is unchecked. B. If the symbol is not visible, open the LonMaker database, launch the LDU Configuration plug-in and verify that the point is mapped appropriately (the LDU configuration was copied, but point mapping was not updated). If the symbol is visible, review the steps listed in 3A above.