

Phoenix Controls Constant Volume Compact Cage Rack Valve combines a factory-calibrated, field-tunable flow rate setting with a mechanical, pressure-independent flow regulator to meet the unique requirements of ventilated cage rack connections to building ventilation systems.

- Short valve body for ease of installation below the ceiling.
- Precise airflow control: The flow rate controller assembly is factory-calibrated to a precise constant volume flow set point.
- Easy-to-use manual setting; includes graduated scale for reference to valve position.
- Self-balancing pressure independent operation: The cage rack valve automatically compensates for system static pressure fluctuations to maintain the airflow set point.
- Simple operation: The valve requires no electrical power or pneumatics to operate, nor are there any flow probes. This simplifies the operation and installation, plus eliminates maintenance.

OPERATION

Volume Control

The valve's shaft/cone assembly is factory pre-set to the flow listed on the room schedule sheet at the time the valve is ordered. The flow setting is easily adjusted in the field to accommodate the wide variety of ventilated cage racks.

Pressure Independent Control

All Phoenix valves maintain a constant airflow by automatically and instantaneously adjusting to changes in static pressure. Each valve has a cone assembly with an internal spring designed to compensate for these changes in duct pressure (see Figs. 1 and 2).

SPECIFICATIONS

Construction

- 16 ga. spun aluminum valve body with continuous welded seam
- Composite Teflon® shaft bearings
- Spring grade stainless steel spring and PPS slider assembly
- Optional white powder coating

Operating Range

- 32-122 °F (0-50 °C) ambient
- 10-90% non-condensing RH

Sound

- Designed for low sound power levels to meet or exceed ASHRAE noise guidelines
- Accel® II valves are designed to reduce sound over all frequencies, but significantly target the lower bands (125-500 Hz) to help eliminate the need for silencers

Performance

- Pressure independent over a 0.6"-3.0" wc (150-750 Pa) drop across valve
- Volume control accurate to $\pm 10\%$, 5 cfm (10 m³/hr) of airflow set point
- Flow range: 30-210 cfm (50-356 m³/hr), factory pre-set to airflow value indicated on order
- No additional straight duct runs needed before or after valve
- Response time to change in duct static pressure: < 1 second
- Optional low static pressure alarm via a pressure switch
- Field adjustable flow set point



© Teflon is a registered trademark of DuPont Co.

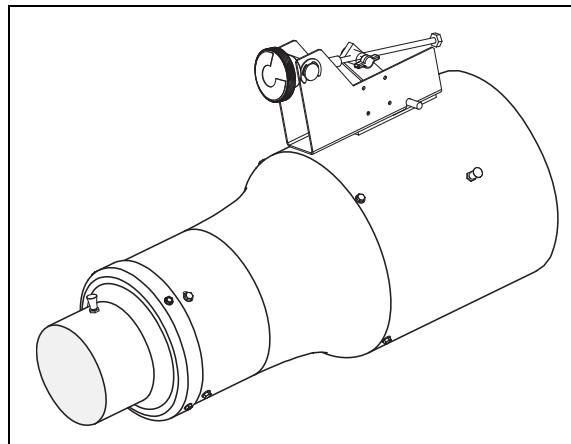

Constant volume compact cage rack valve.

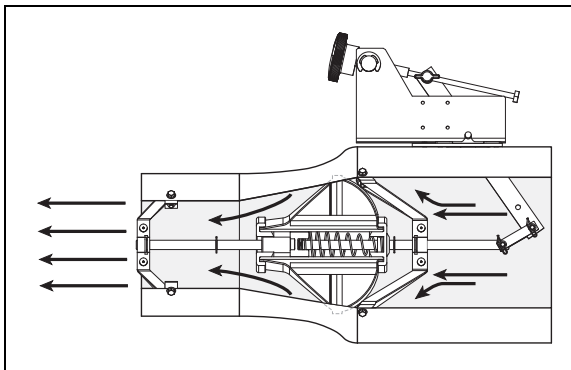

Fig. 1 When there is low static pressure, less force is applied to the cone, which causes the spring within the cone to expand, pulling the cone away from the venturi. The combination of low pressure and the large open area provides the desired flow.

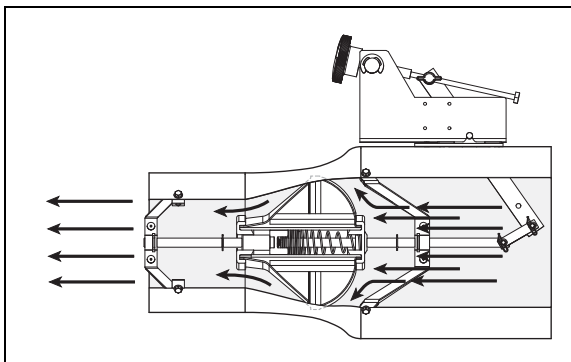
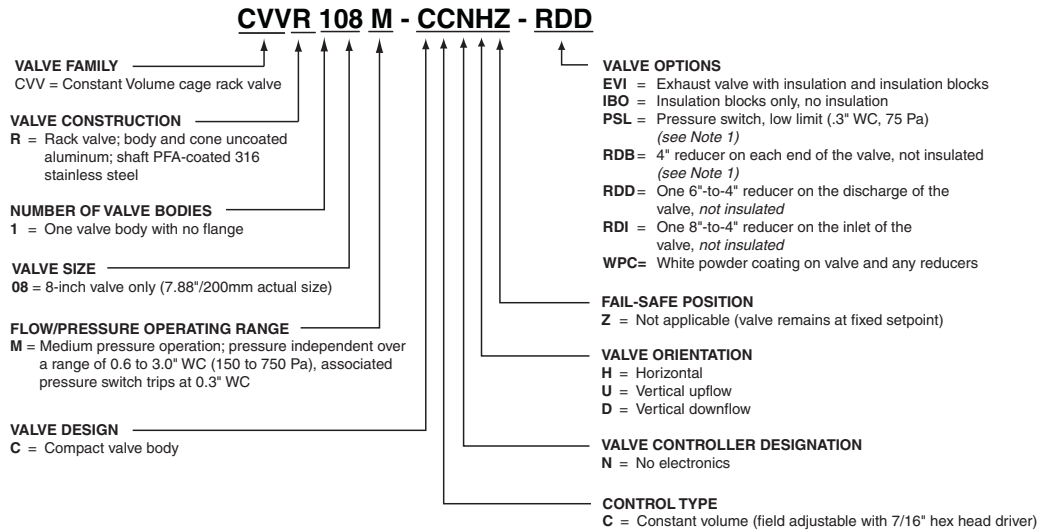

Fig. 2 As static pressure increases force on the cone, the spring compresses and the cone moves into the venturi, reducing the open area. Higher pressure and the smaller opening combine to maintain flow set point.

ORDERING GUIDE



APPLICATIONS

The goal of the vivarium ventilation control system is to stabilize the micro- and macroenvironments. This requires clean, conditioned air to the space and the removal of dirty, heated, moisture-laden air, as well as maintaining proper room pressurization. Phoenix Controls' compact cage rack valves provide airflow control that ensures environmental integrity at the room and device level.

Airflow Control for Rodent Holding Rooms

Phoenix Controls' compact cage rack valves maintain precise constant airflow to and/or from the ventilated racks and eliminate the need for future rebalancing (see Fig. 3). Our pressure-independent valves maintain the proper room supply and exhaust airflows to provide the correct ventilation rate (air changes per hour) and a constant volumetric offset to maintain proper room pressurization.

A variable air volume (VAV) room controller adjusts the supply airflow to meet the

room's thermal or ventilation requirements and adjusts the general exhaust airflow to maintain room pressurization. The room air change rate can be reduced with the flow control strategy shown in Figure 3, since animal odor, other gaseous effluent and part of the heat load are exhausted out of the room, rather than back into the room. The VAV room and constant volume cage rack valve systems allow for a much more flexible and energy conserving approach.

Temperature and relative humidity control is achieved by either Phoenix Controls or the building management system, depending on the engineering design.

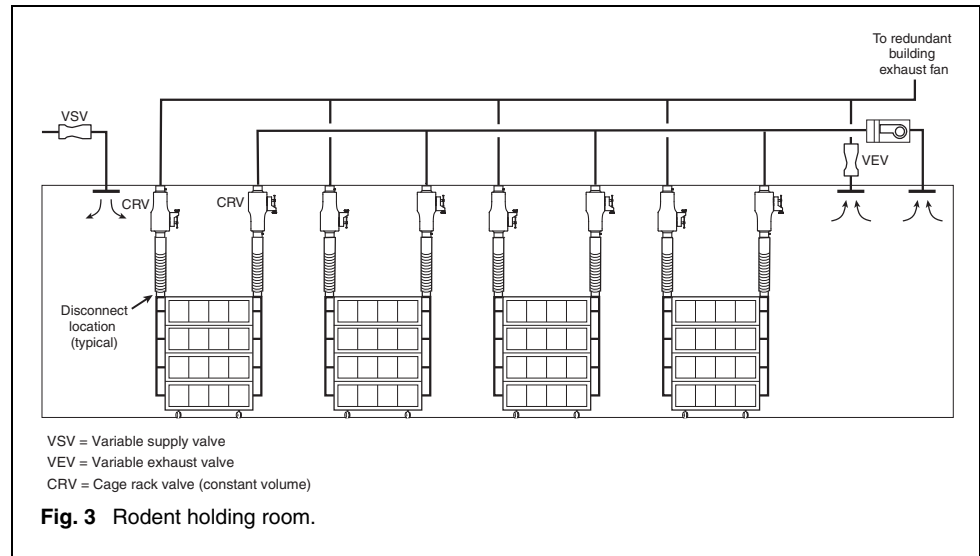

DIMENSIONS & WEIGHT

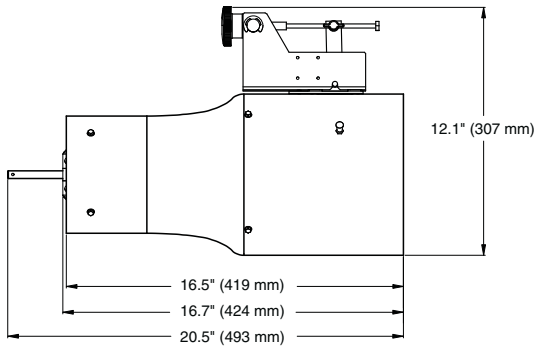

Compact Cage Rack Valve, No Reducers

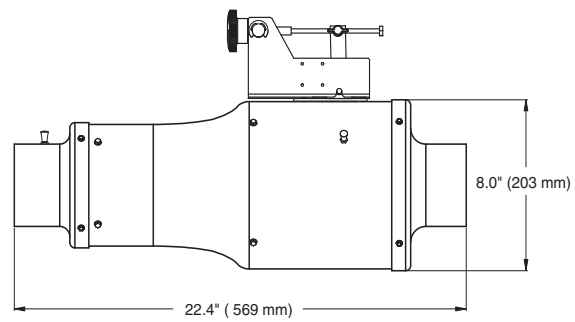

Compact Cage Rack Valve, Two Reducers, Option RDB

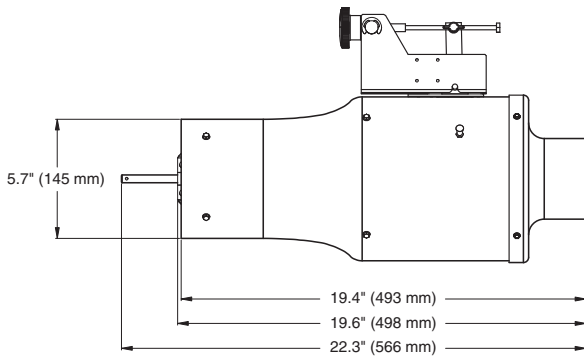

Compact Cage Rack Valve, One Reducer on Inlet, Option RDI

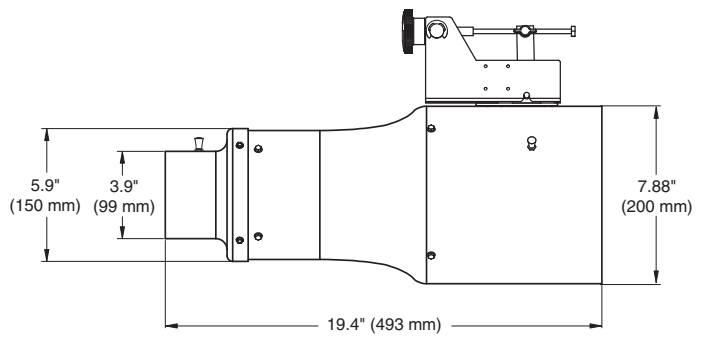

Compact Cage Rack Valve, One Reducer on Discharge, Option RDD

NOTES:

1. Leave 14" (356 mm) access space to flow adjustment mechanism.
2. Dimensions given are accurate to ± 0.13 " (3 mm)
3. Valves need no additional straight runs before or after valve. However, as identified by the dimensions above, the shaft needs up to 3" (76 mm) of unobstructed space in the duct on the inlet side of valves without an inlet reducer in the maximum flow position.
4. Valves without inlet side reducers are shipped with the worm gear mechanism disengaged and tied down (to keep the shaft retracted inside the valve body). The setting mechanism must be re-engaged and secured by the installer prior to operation of the valve with airflow (see Fig. 4).
5. Refer to installation instructions below for additional detail.

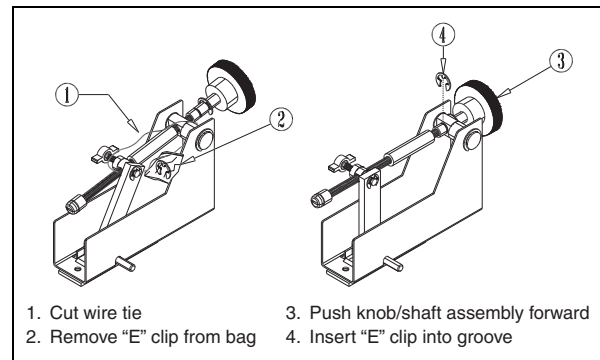

Fig. 4 Flow adjustment connection

Weight

- Approximate weight: 8 lbs (3.6 kg)
- The weight given above is approximate and is listed for reference only. For shipping, add 6 lbs (2.7 kg) for cage rack valves.

INSTALLATION

Procedure for Physical Installation of Valves

1. Read all instructions completely prior to installing valves.
2. Note that tag number on valve label matches the HVAC schedule.
3. Verify the correct airflow direction and orientation of the valve in the ductwork (e.g., horizontal). **NOTE:** Valves mounted out of horizontal or vertical position (as determined by a level) will affect valve performance. Must be within ± 5 degrees of orientation.
4. Allow a minimum of 14" (36 cm) of free unobstructed space around the valve for access. For valves without inlet reducers, allow 3" of unobstructed space in the duct on the valve's inlet side for the shaft to reach the maximum flow position.
5. Flow adjustment connection: Valves without inlet reducers require field connection of the flow adjustment mechanism (see Fig. 4 and instruction label on valve).
6. Install a hanger stock to support the ductwork within 12" (30 cm) of the valve connection.
7. Use duct sealant on all valve/duct/drawband connections (or flange gasket for circular flanges).
8. Follow the appropriate installation diagram (see Fig. 5). **NOTE:** Screws, fasteners, duct sealant, hanger stock, and drawbands are not provided by Phoenix Controls.

Adjusting Valve Flow

1. Compact cage rack valves may need to be field adjusted to compensate for field conditions.
2. Loosen the black locking thumbscrew on the worm gear assembly.
3. If more flow is needed, turn the worm gear knob clockwise, in the direction of the green arrow (see Fig. 6).
4. If less flow is needed, turn the worm gear knob counter clockwise, in the direction of the red arrow (see Fig. 6).
5. Once the correct flow has been achieved, tighten the locking thumbscrew.

POINTS & WIRING *(see submittal wiring diagram for project-specific details)*

Wiring is required only when a pressure switch option has been ordered. Wire between the common and normally open terminals on the pressure switch (see Fig. 7).

- Switch closed = normal operation with fans running
- Switch open = alarm condition (low or no differential static pressure)

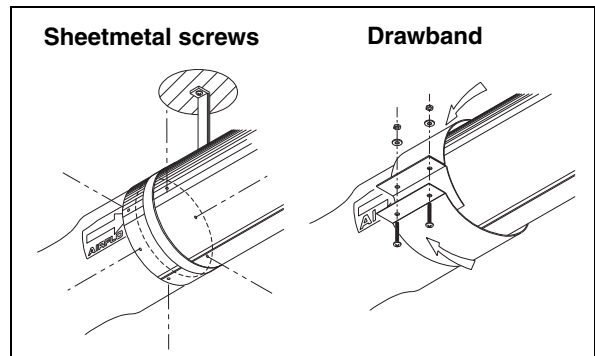

Fig. 5 Valve installation methods. Install valve so that manual adjustment is accessible.

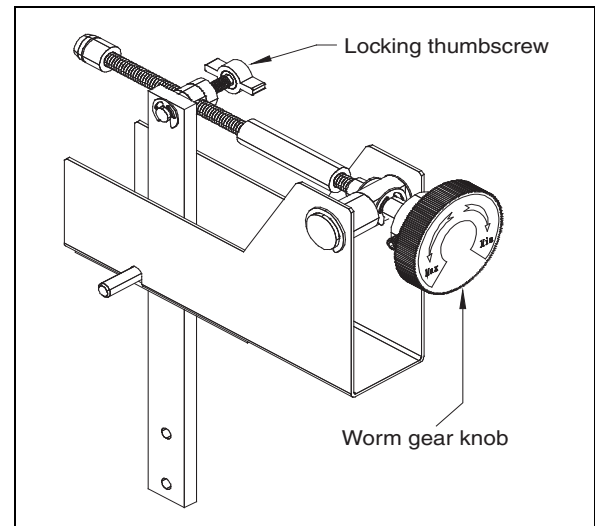

Fig. 6 Field flow adjustment.

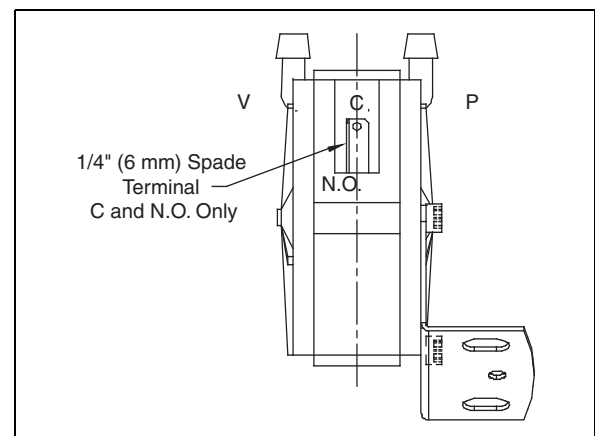

Fig. 7 Wiring connections for optional pressure switch.

MAINTENANCE

Performance

Phoenix Controls constant volume compact cage rack valves require no ongoing preventive maintenance. Once the balancer has verified volume, the valve will provide years of continuous operation.

NOTE: The compact cage rack valve is a precision device that must not be subject to:

- Dripping water or detergents
- Autoclaving
- Spraying of the valve interior

TROUBLESHOOTING

Phoenix Controls valves are one component of an entire vivarium control system. General system troubleshooting often reveals what appears to be a valve problem. Use this chart as a guide.

Problem	Possible Cause/Solution
1. Measured airflow differs from valve setting.	A. Low static pressure across valve (< 0.6" wc, 150 Pa) <ul style="list-style-type: none">• Check fan operation, duct blockage, duct leakage. B. Incorrect valve position. <ul style="list-style-type: none">• Adjust flow as needed (see steps on page 4). C. Flow measurement <ul style="list-style-type: none">• Verify measuring equipment is calibrated properly.• Verify measuring technique (e.g., proper straight runs for traverse).
2. Optional pressure switch indicates an alarm condition.	Low static pressure across valve <ul style="list-style-type: none">• Check fan operation, duct blockage, duct leakage.• Check for blocked or kinked pressure switch tubing.