



ensuring environmental integrity

## Phoenix Controls has now added a Native BACnet® Valve Controller to its portfolio...



The Traccel® and Theris® family of airflow valves are now being offered with an optional BTL certified, Native BACnet controller.

### Why BACnet®? What's the advantage...

In an effort to improve the performance and efficiency of the facilities found in both the Life Science and Healthcare marketplace, building controls are becoming increasingly more complex. The demand for seamless integration all the way down to the room-level devices has led Phoenix Controls to add the option of native BACnet communications to the Traccel and Theris product lines. This enables the Traccel and Theris valve mounted controllers to share data and execute commands initiated from other BACnet-compliant devices. Operational information and control data from the valves is now available to other building controllers and systems through the BACnet MS/TP protocol.

## BACnet®

Like the Phoenix Controls Traccel and Theris LONtALK valve controllers, the BACnet versions are also available in a variety of input/output (I/O) configurations supporting four product platforms (SO, EO, TP, and TX) to accommodate supply or exhaust only, and tracking pair operations in critical applications. (Examples below)

Life Science Solutions		Healthcare Solutions	
	Typical Platform		Typical Platform
Interdisciplinary, Open Space Labs	TP	Patient Rooms	SO/EO
Support Labs	TP	Isolation Rooms	TP/TX
Equipment Alcoves	EO	Operating Suites	TX
Lab Office Spaces	SO	Hospital Pharmacy	TP
Vivariums / Animal Holding Spaces	TX	Rapid Infection Control (RICU)	TX

Inputs and outputs are wired directly to field equipment, and the control sequences are programmable using Phoenix Controls BACnet configuration tool.

**Phoenix Controls**

## About Phoenix Controls

Founded in 1985, Phoenix Controls is a recognized leader in the design and manufacture of precision airflow control systems for use in critical room environments. Our customers include the leading pharmaceutical companies, universities, hospitals, government research facilities and global corporations. We offer innovative airflow control solutions that combine unparalleled safety and performance with value and energy savings.

The Phoenix Controls Quality Management System is registered to ISO 9001:2000.

**Our Core Values** - Of the values we collectively hold, we identify the following as core and use them to guide our behavior and decision making:

**Excellence**- We take pride in the high standards of quality we demand of ourselves and relentlessly pursue excellence in our work, products and service to customers.

**Integrity** - We act with honesty, fairness and ethical behavior in everything we do and are accountable by taking ownership of our actions and meeting our commitments.

**Creativity** - It is the spark of invention and the cornerstone of our organization. Our inspiration comes from an environment that embraces learning, experimentation and innovative thinking.

## Traccel® and Theris® BACnet Control Features

- Airflow / Volumetric offset control
- Temperature and occupancy control
- Humidity Control
- Pressure Monitoring
- Multiple Emergency Modes
- Floating Point Re-heat
- Modulating Re-heat
- Discharge air Sensors and IAQ Sensors
- Air Flow Shut-off or Isolation capabilities

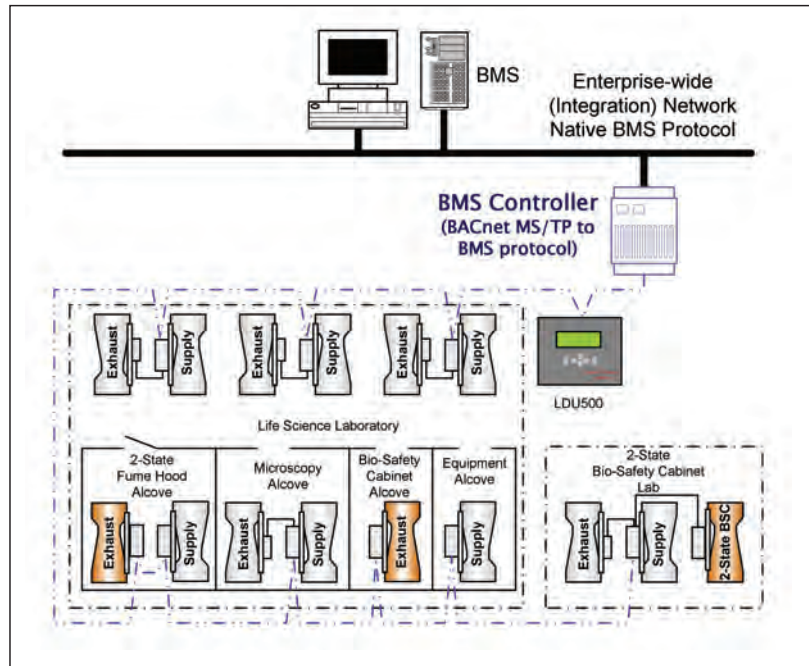

## Traccel and Theris Total BACnet Solutions...

To compliment the BACnet Valve Controllers and provide complete room level solutions, Phoenix Controls provides quality BACnet ancillary devices like Local Display units (LDU), and Phoenix Temperature Controllers (PTC). In addition, Phoenix also offers multiple analog temperature and humidity sensors that hardwire directly to the BACnet Room Level Controller.



The Phoenix Controls LDU 500 is a fully programmable local display unit for BACnet systems. It connects directly to the MS/TP LAN of a BACnet system and can be wall mounted. The LDU-500 has an easy-to-use keypad and a 4-line by 20-character LCD to allow an operator to query and adjust system values..

**To learn more about how this product can help you save on installation costs for your next project, and for additional information and a listing of our global offices, please visit our Web site at [www.phoenixcontrols.com](http://www.phoenixcontrols.com) or call (800) 340-0007.**

Phoenix Controls is a wholly owned subsidiary of Honeywell International, Inc. Phoenix Controls and Accel are registered trademarks of Phoenix Controls. This product may be covered by one or more of the following patents: 05545086, 05425779, 05385505, 05304093, 05251665, 05240455, their foreign counterparts and other pending patents. © 2009 Phoenix Controls 6/09 Printed in U.S.A. MKT-0231 MPC-1388